



SH1107

128 X 128 Dot Matrix OLED/PLED Segment/Common Driver with Controller

Features

- Support maximum 128 X 128 dot matrix panel
- Embedded 128 X 128 bits SRAM
- Operating voltage:
 - Logic voltage supply: $V_{DD} = 1.65V - 3.5V$
 - DC-DC voltage supply: $AV_{DD} = 2.4V - 3.5V$
 - OLED Operating voltage supply: $V_{pp} = 7.0V - 16.5V$
- Maximum segment output current: 500 μ A
- Maximum common sink current: 64mA
- 8-bit 6800-series parallel interface, 8-bit 8080-series parallel interface, and 3-wire & 4-wire serial peripheral interface.
- 400KHz fast I²C bus interface
- Programmable frame frequency and multiplexing ratio
- Row re-mapping and column re-mapping
- Vertical scrolling
- On-chip oscillator
- Available internal DC-DC converter
- 256-step contrast control on monochrome passive OLED panel
- Low power consumption
 - Sleep mode: <5 μ A
- Wide range of operating temperatures: -40 to +85°C
- Available in COG form.

General Description

SH1107 is a single-chip CMOS OLED/PLED driver with controller for organic/polymer light emitting diode dot-matrix graphic display system. SH1107 consists of 128 segments, 128 commons that can support a maximum display resolution of 128 X 128. It is designed for Common Cathode type OLED panel.

SH1107 embeds with contrast control, display RAM oscillator and efficient DC-DC converter, which reduces the number of external components and power consumption. SH1107 is suitable for a wide range of compact portable applications, such as sub-display of mobile phone, calculator and MP3 player, etc.



Block Diagram

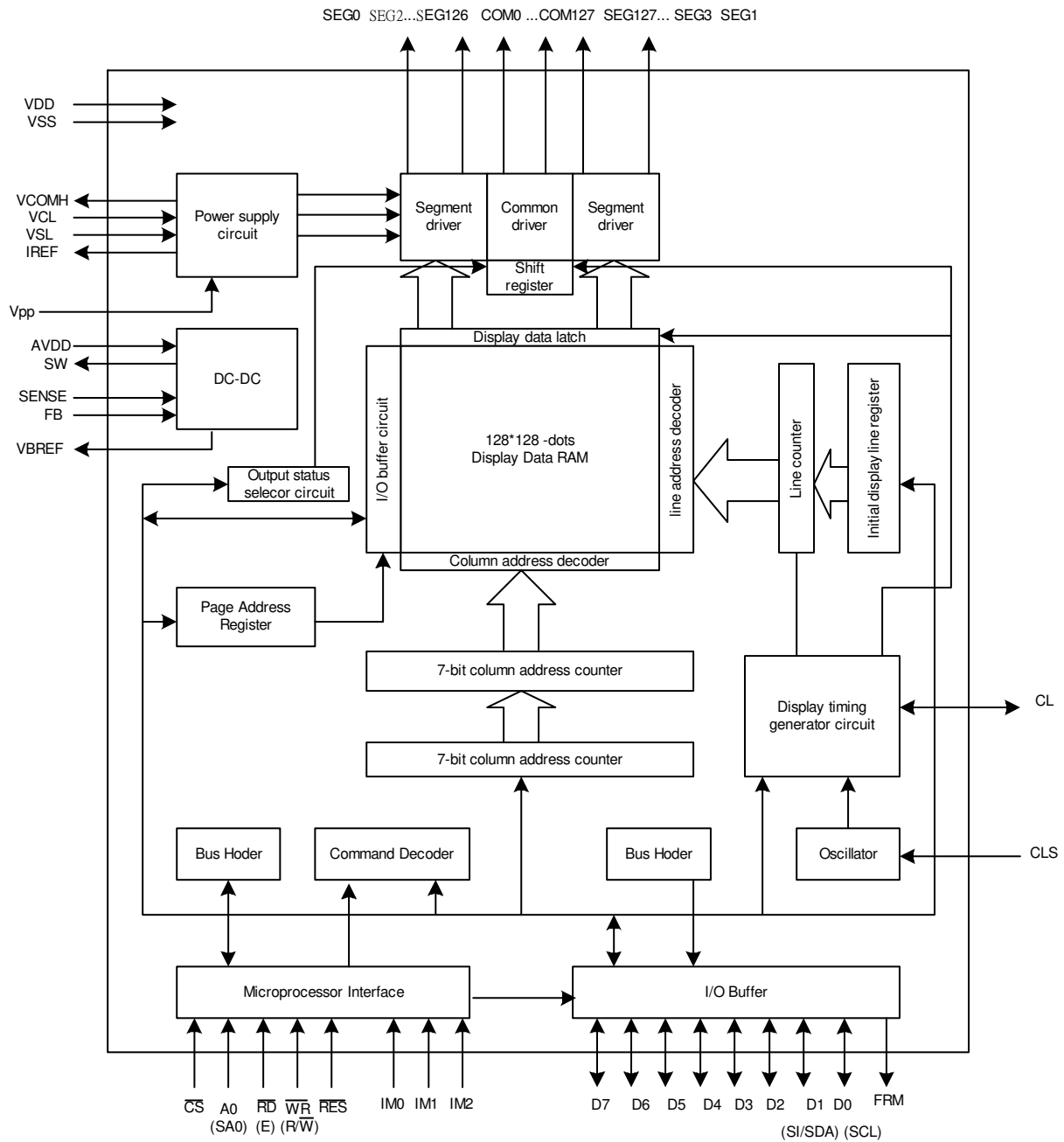

Figure 1 SH1107 Block Diagram



Pad Description

Power Supply

Pad NO.	Symbol	I/O	Description
34, 35	VDD	Supply	1.65 - 3.5V Power supply for logic and input.
39	VDD	O	VDD output for pad option.
16, 17	AVDD	Supply	2.4 - 3.5V power supply for the internal buffer of the DC-DC voltage converter.
25	VSS	Supply	Ground for analog.
26	VSS	Supply	Ground for logic.
2-6,27 68-72	VSS	Supply	Ground for buffer.
37, 41	VSS	O	Ground output for pad option.
23, 24	VSL	Supply	This is a segment voltage reference pad. This pad should be connected to VSS externally.
28-32	VCL	Supply	This is a common voltage reference pad. This pad should be connected to VSS externally.
7-10 21-22 64-67	VPP	Supply	This is the most positive voltage supply pad of the chip. It should be supplied externally.

OLED Driver Supplies

Pad NO.	Symbol	I/O	Description
42-43	IREF	O	This is a segment current reference pad. A resistor should be connected between this pad and VSS. Set the current at 15.625 μ A.
11-13	VCOMH	O	This is a pad for the voltage output high level for common signals. A capacitor should be connected between this pad and VSS.
18	VBREF	O	This is an internal voltage reference pad for booster circuit. A capacitor should be connected between this pad and VSS.
14-15	SW	O	This is an output pad driving the gate of the external NMOS of the booster circuit.
19	FB	I	This is a feedback resistor input pad for the booster circuit. It is used to adjust the booster output voltage level, VPP
20	SENSE	I	This is a source current pad of the external NMOS of the booster circuit.



System Bus Connection Pads

Pad NO.	Symbol	I/O	Description																								
48	CL	I/O	This pad is the system clock input. When internal clock is enabled, this pad should be Left open. The internal clock is output from this pad. When internal oscillator is disabled, this pad receives display clock signal from external clock source.																								
33	CLS	I	This is the internal clock enable pad. CLS = "H": Internal oscillator circuit is enabled. CLS = "L": Internal oscillator circuit is disabled (require external input). When CLS = "L", an external clock source must be connected to the CL pad for normal operation.																								
36 38 40	IM0 IM1 IM2	I	These are the MPU interface mode select pads. <table border="1" style="margin-left: 20px;"> <thead> <tr> <th></th> <th>8080</th> <th>I²C</th> <th>6800</th> <th>4-wire SPI</th> <th>3-wire SPI</th> </tr> </thead> <tbody> <tr> <td>IM0</td> <td>0</td> <td>0</td> <td>0</td> <td>0</td> <td>1</td> </tr> <tr> <td>IM1</td> <td>1</td> <td>1</td> <td>0</td> <td>0</td> <td>0</td> </tr> <tr> <td>IM2</td> <td>1</td> <td>0</td> <td>1</td> <td>0</td> <td>0</td> </tr> </tbody> </table>		8080	I ² C	6800	4-wire SPI	3-wire SPI	IM0	0	0	0	0	1	IM1	1	1	0	0	0	IM2	1	0	1	0	0
	8080	I ² C	6800	4-wire SPI	3-wire SPI																						
IM0	0	0	0	0	1																						
IM1	1	1	0	0	0																						
IM2	1	0	1	0	0																						
49	\overline{CS}	I	This pad is the chip select input. When \overline{CS} = "L", then the chip select becomes active, and data/command I/O is enabled.																								
50	\overline{RES}	I	This is a reset signal input pad. When \overline{RES} is set to "L", the settings are initialized. The reset operation is performed by the \overline{RES} signal level.																								
51	A0 (SA0)	I	This is the Data/Command control pad that determines whether the data bits are data or a command. A0 = "H": the inputs at D0 to D7 are treated as display data. A0 = "L": the inputs at D0 to D7 are transferred to the command registers. In I ² C interface, this pad serves as SA0 to distinguish the different address of OLED driver.																								
52	\overline{WR} (R/ \overline{W})	I	This is a MPU interface input pad. When connected to an 8080 MPU, this is active LOW. This pad connects to the 8080 MPU \overline{WR} signal. The signals on the data bus are latched at the rising edge of the \overline{WR} signal. When connected to a 6800 Series MPU: This is the read/write control signal input terminal. When R/ \overline{W} = "H": Read. When R/ \overline{W} = "L": Write.																								
53	\overline{RD} (E)	I	This is a MPU interface input pad. When connected to an 8080 series MPU, it is active LOW. This pad is connected to the \overline{RD} signal of the 8080 series MPU, and the data bus is in an output status when this signal is "L". When connected to a 6800 series MPU, this is active HIGH. This is used as an enable clock input of the 6800 series MPU.																								
54-61	D0 - D7 (SCL) (SI/SDA)	I/O I I/O	This is an 8-bit bi-directional data bus that connects to an 8-bit or 16-bit standard MPU data bus. When the serial interface is selected, then D0 serves as the serial clock input pad (SCL) and D1 serves as the serial data input pad (SI). At this time, D2 to D7 are set to high impedance. When the I ² C interface is selected, then D0 serves as the serial clock input pad (SCL) and D1 serves as the serial data input pad (SDA). At this time, D2 to D7 are set to high impedance.																								
47	FRM	O	This pad is No Connection pad, Its signal varies with the frame frequency. Its voltage is equal to VDD when the last common output of every frame is active, and is equal to Vss during other time.																								

**OLED Drive Pads**

Pad NO.	Symbol	I/O	Description
271-334	SEG126,124,.....4,2,0	O	These pads are even Segment signal output for OLED display.
75-138	SEG1,3,.....125,127	O	These pads are odd Segment signal output for OLED display.
140-220 223-269	COM127- 0	O	These pads are Common signal output for OLED display.

Test Pads

Pad NO.	Symbol	I/O	Description
44	TEST1	I	Test pad, internal pull low, no connection for user.
45	TEST2	O	Test pad, no connection for user.
46	TEST3	I	Test pad, no connection for user.
1, 62, 63, 73, 74, 139, 221, 222, 270, 335	Dummy	-	Dummy pads, no connection for user



Pad Configuration

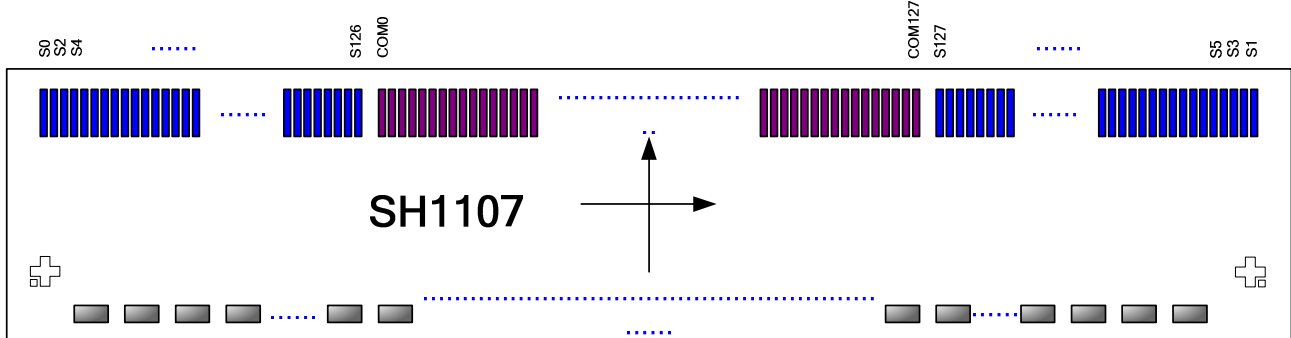

Chip Outline Dimensions

Item	Pad No.	Size (μm)	
		X	Y
Chip boundary	-	8194	670
Chip height	All pads	300	
Bump size	I/O	95	40
	SEG	15	110
	COM	15	110
Pad pitch	COM	30	
	SEG	28	
	I/O	110	
Bump height	All pads	9±2	

Alignment Mark Location

Unit: μm

NO	X	Y
ALK_L	-3960	-163
ALK_R	3960	-163

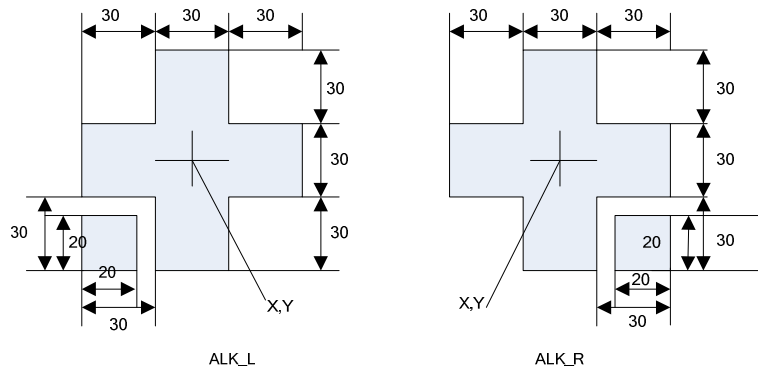



Pad Location (Total: pads)

unit: μm

Pad No.	Designation	X	Y	Pad No.	Designation	X	Y	Pad No.	Designation	X	Y	Pad No.	Designation	X	Y
1	DUMMY	-3960	-283	82	SEG[15]	3823	252	163	COM[104]	1350	252	244	COM[25]	-1290	252
2	GND	-3850	-283	83	SEG[17]	3795	252	164	COM[103]	1320	252	245	COM[24]	-1320	252
3	GND	-3740	-283	84	SEG[19]	3767	252	165	COM[102]	1290	252	246	COM[23]	-1350	252
4	GND	-3630	-283	85	SEG[21]	3739	252	166	COM[101]	1260	252	247	COM[22]	-1380	252
5	GND	-3520	-283	86	SEG[23]	3711	252	167	COM[100]	1230	252	248	COM[21]	-1410	252
6	GND	-3410	-283	87	SEG[25]	3683	252	168	COM[99]	1200	252	249	COM[20]	-1440	252
7	VPP	-3300	-283	88	SEG[27]	3655	252	169	COM[98]	1170	252	250	COM[19]	-1470	252
8	VPP	-3190	-283	89	SEG[29]	3627	252	170	COM[97]	1140	252	251	COM[18]	-1500	252
9	VPP	-3080	-283	90	SEG[31]	3599	252	171	COM[96]	1110	252	252	COM[17]	-1530	252
10	VPP	-2970	-283	91	SEG[33]	3571	252	172	COM[95]	1080	252	253	COM[16]	-1560	252
11	VCOMH	-2860	-283	92	SEG[35]	3543	252	173	COM[94]	1050	252	254	COM[15]	-1590	252
12	VCOMH	-2750	-283	93	SEG[37]	3515	252	174	COM[93]	1020	252	255	COM[14]	-1620	252
13	VCOMH	-2640	-283	94	SEG[39]	3487	252	175	COM[92]	990	252	256	COM[13]	-1650	252
14	SW	-2530	-283	95	SEG[41]	3459	252	176	COM[91]	960	252	257	COM[12]	-1680	252
15	SW	-2420	-283	96	SEG[43]	3431	252	177	COM[90]	930	252	258	COM[11]	-1710	252
16	AVDD	-2310	-283	97	SEG[45]	3403	252	178	COM[89]	900	252	259	COM[10]	-1740	252
17	AVDD	-2200	-283	98	SEG[47]	3375	252	179	COM[88]	870	252	260	COM[9]	-1770	252
18	VBREF	-2090	-283	99	SEG[49]	3347	252	180	COM[87]	840	252	261	COM[8]	-1800	252
19	FB	-1980	-283	100	SEG[51]	3319	252	181	COM[86]	810	252	262	COM[7]	-1830	252
20	SENSE	-1870	-283	101	SEG[53]	3291	252	182	COM[85]	780	252	263	COM[6]	-1860	252
21	VPP	-1760	-283	102	SEG[55]	3263	252	183	COM[84]	750	252	264	COM[5]	-1890	252
22	VPP	-1650	-283	103	SEG[57]	3235	252	184	COM[83]	720	252	265	COM[4]	-1920	252
23	VSL	-1540	-283	104	SEG[59]	3207	252	185	COM[82]	690	252	266	COM[3]	-1950	252
24	VSL	-1430	-283	105	SEG[61]	3179	252	186	COM[81]	660	252	267	COM[2]	-1980	252
25	GND(ana)	-1320	-283	106	SEG[63]	3151	252	187	COM[80]	630	252	268	COM[1]	-2010	252
26	GND(logic)	-1210	-283	107	SEG[65]	3123	252	188	COM[79]	600	252	269	COM[0]	-2040	252
27	GND(buf)	-1100	-283	108	SEG[67]	3095	252	189	COM[78]	570	252	270	DUMMY	-2070	252
28	VCL	-990	-283	109	SEG[69]	3067	252	190	COM[77]	540	252	271	SEG[126]	-2255	252
29	VCL	-880	-283	110	SEG[71]	3039	252	191	COM[76]	510	252	272	SEG[124]	-2283	252
30	VCL	-770	-283	111	SEG[73]	3011	252	192	COM[75]	480	252	273	SEG[122]	-2311	252
31	VCL	-660	-283	112	SEG[75]	2983	252	193	COM[74]	450	252	274	SEG[120]	-2339	252
32	VCL	-550	-283	113	SEG[77]	2955	252	194	COM[73]	420	252	275	SEG[118]	-2367	252
33	VCS	-440	-283	114	SEG[79]	2927	252	195	COM[72]	390	252	276	SEG[116]	-2395	252
34	VCC	-330	-283	115	SEG[81]	2899	252	196	COM[71]	360	252	277	SEG[114]	-2423	252
35	VCC	-220	-283	116	SEG[83]	2871	252	197	COM[70]	330	252	278	SEG[112]	-2451	252
36	IMO	-110	-283	117	SEG[85]	2843	252	198	COM[69]	300	252	279	SEG[110]	-2479	252
37	GND	0	-283	118	SEG[87]	2815	252	199	COM[68]	270	252	280	SEG[108]	-2507	252
38	IM1	110	-283	119	SEG[89]	2787	252	200	COM[67]	240	252	281	SEG[106]	-2535	252
39	VCC	220	-283	120	SEG[91]	2759	252	201	COM[66]	210	252	282	SEG[104]	-2563	252
40	IM2	330	-283	121	SEG[93]	2731	252	202	COM[65]	180	252	283	SEG[102]	-2591	252
41	GND	440	-283	122	SEG[95]	2703	252	203	COM[64]	150	252	284	SEG[100]	-2619	252
42	IREF	550	-283	123	SEG[97]	2675	252	204	COM[63]	120	252	285	SEG[98]	-2647	252
43	IREF	660	-283	124	SEG[99]	2647	252	205	COM[62]	90	252	286	SEG[96]	-2675	252
44	TEST1	770	-283	125	SEG[101]	2619	252	206	COM[61]	60	252	287	SEG[94]	-2703	252
45	TEST2	880	-283	126	SEG[103]	2591	252	207	COM[60]	30	252	288	SEG[92]	-2731	252
46	TEST3	990	-283	127	SEG[105]	2563	252	208	COM[59]	0	252	289	SEG[90]	-2759	252
47	FRM	1100	-283	128	SEG[107]	2535	252	209	COM[58]	-30	252	290	SEG[88]	-2787	252
48	CL	1210	-283	129	SEG[109]	2507	252	210	COM[57]	-60	252	291	SEG[86]	-2815	252
49	CSB	1320	-283	130	SEG[111]	2479	252	211	COM[56]	-90	252	292	SEG[84]	-2843	252
50	RESB	1430	-283	131	SEG[113]	2451	252	212	COM[55]	-120	252	293	SEG[82]	-2871	252
51	A0	1540	-283	132	SEG[115]	2423	252	213	COM[54]	-150	252	294	SEG[80]	-2899	252
52	WRB	1650	-283	133	SEG[117]	2395	252	214	COM[53]	-180	252	295	SEG[78]	-2927	252
53	RDB	1760	-283	134	SEG[119]	2367	252	215	COM[52]	-210	252	296	SEG[76]	-2955	252
54	D[0]	1870	-283	135	SEG[121]	2339	252	216	COM[51]	-240	252	297	SEG[74]	-2983	252
55	D[1]	1980	-283	136	SEG[123]	2311	252	217	COM[50]	-270	252	298	SEG[72]	-3011	252
56	D[2]	2090	-283	137	SEG[125]	2283	252	218	COM[49]	-300	252	299	SEG[70]	-3039	252
57	D[3]	2200	-283	138	SEG[127]	2255	252	219	COM[48]	-330	252	300	SEG[68]	-3067	252
58	D[4]	2310	-283	139	DUMMY	2070	252	220	COM[47]	-360	252	301	SEG[66]	-3095	252
59	D[5]	2420	-283	140	COM[127]	2040	252	221	DUMMY	-390	252	302	SEG[64]	-3123	252
60	D[6]	2530	-283	141	COM[126]	2010	252	222	DUMMY	-630	252	303	SEG[62]	-3151	252
61	D[7]	2640	-283	142	COM[125]	1980	252	223	COM[46]	-660	252	304	SEG[60]	-3179	252
62	DUMMY	2750	-283	143	COM[124]	1950	252	224	COM[45]	-690	252	305	SEG[58]	-3207	252
63	DUMMY	2860	-283	144	COM[123]	1920	252	225	COM[44]	-720	252	306	SEG[56]	-3235	252
64	VPP	2970	-283	145	COM[122]	1890	252	226	COM[43]	-750	252	307	SEG[54]	-3263	252
65	VPP	3080	-283	146	COM[121]	1860	252	227	COM[42]	-780	252	308	SEG[52]	-3291	252
66	VPP	3190	-283	147	COM[120]	1830	252	228	COM[41]	-810	252	309	SEG[50]	-3319	252
67	VPP	3300	-283	148	COM[119]	1800	252	229	COM[40]	-840	252	310	SEG[48]	-3347	252
68	GND	3410	-283	149	COM[118]	1770	252	230	COM[39]	-870	252	311	SEG[46]	-3375	252
69	GND	3520	-283	150	COM[117]	1740	252	231	COM[38]	-900	252	312	SEG[44]	-3403	252
70	GND	3630	-283	151	COM[116]	1710	252	232	COM[37]	-930	252	313	SEG[42]	-3431	252
71	GND	3740	-283	152	COM[115]	1680	252	233	COM[36]	-960	252	314	SEG[40]	-3459	252
72	GND	3850	-283	153	COM[114]	1650	252	234	COM[35]	-990	252	315	SEG[38]	-3487	252
73	DUMMY	3960	-283	154	COM[113]	1620	252	235	COM[34]	-1020	252	316	SEG[36]	-3515	252
74	DUMMY	4070	252	155	COM[112]	1590	252	236	COM[33]	-1050	252	317	SEG[34]	-3543	252
75	SEG[1]	4019	252	156	COM[111]	1560	252	237	COM[32]	-1080	252	318	SEG[32]	-3571	252
76	SEG[3]	3991	252	157	COM[110]	1530	252	238	COM[31]	-1110	252	319	SEG[30]	-3599	252
77	SEG[5]	3963	252	158	COM[109]	1500	252	239	COM[30]	-1140	252	320	SEG[28]	-3627	252
78	SEG[7]	3935	252	159	COM[108]	1470	252	240	COM[29]	-1170	252	321	SEG[26]	-3655	252
79	SEG[9]	3907	252	160	COM[107]	1440	252	241	COM[28]	-1200	252	322	SEG[24]	-3683	252
80	SEG[11]	3879	252	161	COM[106]	1410	252	242	COM[27]	-1230	252	323	SEG[22]	-3711	252
81	SEG[13]	3851	252	162	COM[105]	1380	252	243	COM[26]	-1260	252	324	SEG[20]	-3739	252



Pad No.	Designation	X	Y
325	SEG[18]	-3767	252
326	SEG[16]	-3795	252
327	SEG[14]	-3823	252
328	SEG[12]	-3851	252
329	SEG[10]	-3879	252
330	SEG[8]	-3907	252
331	SEG[6]	-3935	252
332	SEG[4]	-3963	252
333	SEG[2]	-3991	252
334	SEG[0]	-4019	252



Functional Description

Microprocessor Interface Selection

The 8080-Parallel Interface, 6800-Parallel Interface, Serial Interface (SPI) or I²C Interface can be selected by different selections of IM0~2 as shown in Table 1.

Table 1

Interface	Config			Data signal								Control signal				
	IM0	IM1	IM2	D7	D6	D5	D4	D3	D2	D1	D0	E/ \overline{RD}	\overline{WR}	\overline{CS}	A0	\overline{RES}
6800	0	0	1	D7	D6	D5	D4	D3	D2	D1	D0	E	R/ \overline{W}	\overline{CS}	A0	\overline{RES}
8080	0	1	1	D7	D6	D5	D4	D3	D2	D1	D0	\overline{RD}	\overline{WR}	\overline{CS}	A0	\overline{RES}
4-Wire SPI	0	0	0	Hz (Note1)						SI	SCL	Pull High or Low	\overline{CS}	A0	\overline{RES}	
3-Wire SPI	1	0	0	Hz (Note1)						SI	SCL	Pull High or Low	\overline{CS}	Pull Low	\overline{RES}	
I ² C	0	1	0	Hz (Note1)						SDA	SCL	Pull High or Low	Pull Low	SA0	\overline{RES}	

Note1: When Serial Interface (SPI) or I²C Interface is selected, D7~D2 is Hz. D7~D2 is recommended to connect the VDD or VSS. It is also allowed to leave D7~D2 unconnected.

6800-series Parallel Interface

The parallel interface consists of 8 bi-directional data pads (D7-D0), \overline{WR} (R/ \overline{W}), \overline{RD} (E), A0 and \overline{CS} . When \overline{WR} (R/ \overline{W}) = "H", read operation from the display RAM or the status register occurs. When \overline{WR} (R/ \overline{W}) = "L", Write operation to display data RAM or internal command registers occurs, depending on the status of A0 input. The \overline{RD} (E) input serves as data latch signal (clock) when it is "H", provided that \overline{CS} = "L" as shown in Table 2.

Table 2

IM0	IM1	IM2	Type	\overline{CS}	A0	\overline{RD}	\overline{WR}	D0 to D7
0	0	1	6800 microprocessor bus	\overline{CS}	A0	E	R/ \overline{W}	D0 to D7

In order to match the operating frequency of display RAM with that of the microprocessor, some pipeline processing are internally performed, which require the insertion of a dummy read before the first actual display data read. This is shown in [Figure 2](#) below.

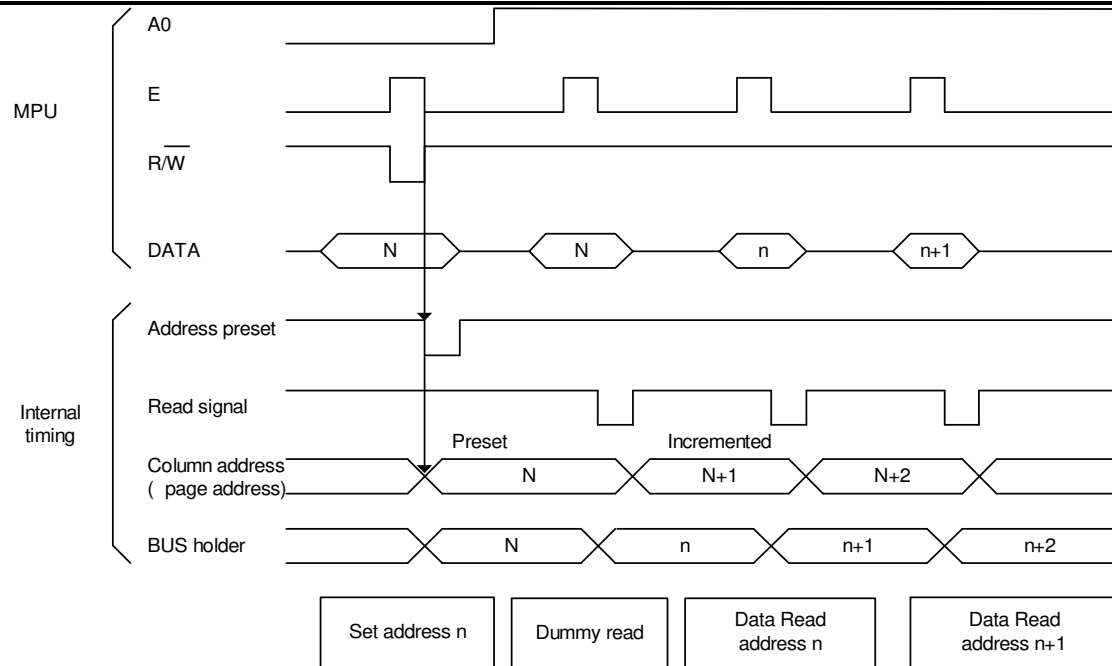

Figure 2

8080-series Parallel Interface

The parallel interface consists of 8 bi-directional data pads (D7-D0), \overline{WR} (R/ \overline{W}), \overline{RD} (E), A0 and \overline{CS} . The \overline{RD} (E) input serves as data read latch signal (clock) when it is "L" provided that \overline{CS} = "L". Display data or status register read is controlled by A0 signal. The \overline{WR} (R/ \overline{W}) input serves as data write latch signal (clock) when it is "L" and provided that \overline{CS} = "L". Display data or command register write is controlled by A0 as shown in Table 3.

Table 3

IM0	IM1	IM2	Type	\overline{CS}	A0	\overline{RD}	\overline{WR}	D0 to D7
0	1	1	8080 microprocessor bus	\overline{CS}	A0	\overline{RD}	\overline{WR}	D0 to D7

Similar to 6800-series interface, a dummy read is also required before the first actual display data read.

Data Bus Signals

The SH1107 identifies the data bus signal according to A0, \overline{RD} (E) and \overline{WR} (R/ \overline{W}) signals.

Table 4

Common	6800 processor (R/ \overline{W})	8080 processor		Function
		\overline{RD}	\overline{WR}	
A0				
1	1	0	1	Reads display data.
1	0	1	0	Writes display data.
0	1	0	1	Reads status.
0	0	1	0	Writes control data in internal register. (Command)



4 Wire Serial Interface (4-wire SPI)

The serial interface consists of serial clock SCL, serial data SI, A0 and \overline{CS} . SI is shifted into an 8-bit shift register on every rising edge of SCL in the order of D7, D6 ... and D0. A0 is sampled on every eighth clock and the data byte in the shift register is written to the display data RAM (A0=1) or command register (A0=0) in the same clock. See Figure 3.

Table 5

IM0	IM1	IM2	Type	\overline{CS}	A0	\overline{RD}	\overline{WR}	D0	D1	D2 to D7
0	0	0	4-wire SPI	\overline{CS}	A0	-	-	SCL	SI	(Hz)

Note: “-” pin must always be HIGH or LOW. D7~D2 is recommended to connect the VDD or VSS. It’s also allowed to leave D7~D2 unconnected.

The serial interface is initialized when \overline{CS} is high. In this state, SCL clock pulse or SDI data have no effect. A falling edge on \overline{CS} enables the serial interface and indicates the start of data transmission. The SPI is also able to work properly when the \overline{CS} always keep low, but it is not recommended.

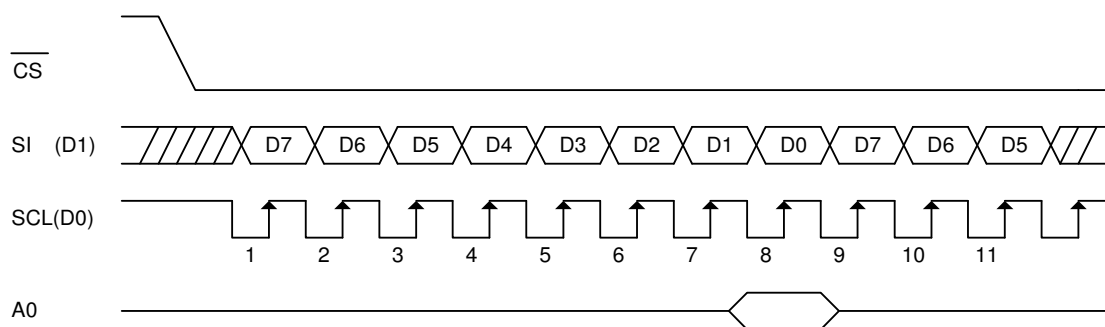

Figure 3 4-wire SPI data transfer

- When the chip is not active, the shift registers and the counter are reset to their initial statuses.
- Read is not possible while in serial interface mode.
- Caution is required on the SCL signal when it comes to line-end reflections and external noise. We recommend the operation be rechecked on the actual equipment.



3 Wire Serial Interface (3-wire SPI)

The 3 wire serial interface consists of serial clock SCL, serial data SI, and \overline{CS} . SI is shifted into a 9-bit shift register on every rising edge of SCL in the order of D/\overline{C} , D7, D6 ... D0. The D/\overline{C} bit (first of the 9 bit) will determine the transferred data is written to the display data RAM ($D/\overline{C}=1$) or command register ($D/\overline{C}=0$). See Figure 4.

Table 6

IM0	IM1	IM2	Type	\overline{CS}	A0	\overline{RD}	\overline{WR}	D0	D1	D2 to D7
1	0	0	3-wire SPI	\overline{CS}	Pull Low	-	-	SCL	SI	(Hz)

Note: “-” pin must always be HIGH or LOW. D7~ D2 is recommended to connect the VDD or VSS. It is also allowed to leave D7~ D2 unconnected.

The serial interface is initialized when \overline{CS} is high. In this state, SCL clock pulse or SDI data have no effect. A falling edge on \overline{CS} enables the serial interface and indicates the start of data transmission. The SPI is also able to work properly when the \overline{CS} always keep low, but it is not recommended.

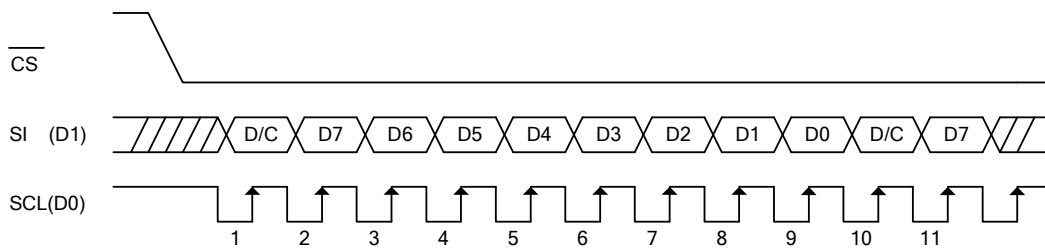

Figure 4 3-wire SPI data transfer

- When the chip is not active, the shift registers and the counter are reset to their initial statuses.
- Read is not possible while in serial interface mode.
- Caution is required on the SCL signal when it comes to line-end reflections and external noise. We recommend the operation be rechecked on the actual equipment.



I²C-bus Interface

The SH1107 can transfer data via a standard I²C-bus and has slave mode only in communication. The command or RAM data can be written into the chip and the status and RAM data can be read out of the chip.

Table 7

IM0	IM1	IM2	Type	\overline{CS}	A0	\overline{RD}	\overline{WR}	D0	D1	D2 to D7
0	1	0	I ² C Interface	Pull Low	SA0	-	-	SCL	SDA	(Hz)

Note: “-” pin must always be HIGH or LOW. D7~ D2 is recommended to connect the V_{DD} or V_{SS}. It is also allowed to leave D7~ D2 unconnected.

\overline{CS} Signal could always pull low in I²C-bus application.

Characteristics of the I²C-bus

The I²C-bus is for bi-directional, two-line communication between different ICs or modules. The two lines are a serial data line (SDA) and a serial clock line (SCL). Both lines must be connected to a positive supply via a pull-up resistor. Data transfer may be initiated only when the bus is not busy.

Note: The positive supply of pull-up resistor must equal to the value of V_{DD}.

Bit Transfer

One data bit is transferred during each clock pulse. The data on the SDA line must remain stable during the HIGH period of the clock pulse as changes in the data line at this time will be interpreted as a control signal.

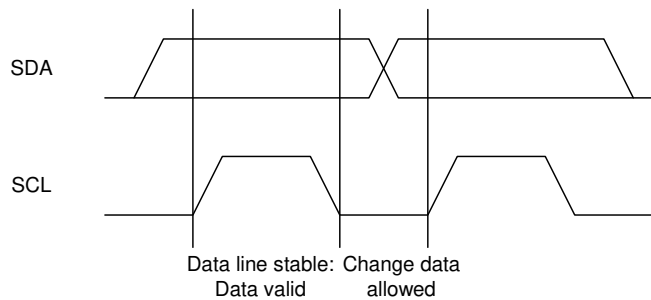

Figure 5 Bit Transfer



Start and Stop conditions

Both data and clock lines remain HIGH when the bus is not busy. A HIGH-to-LOW transition of the data line, while the clock is HIGH is defined as the START condition (S). A LOW-to-HIGH transition of the data line while the clock is HIGH is defined as the STOP condition (P).

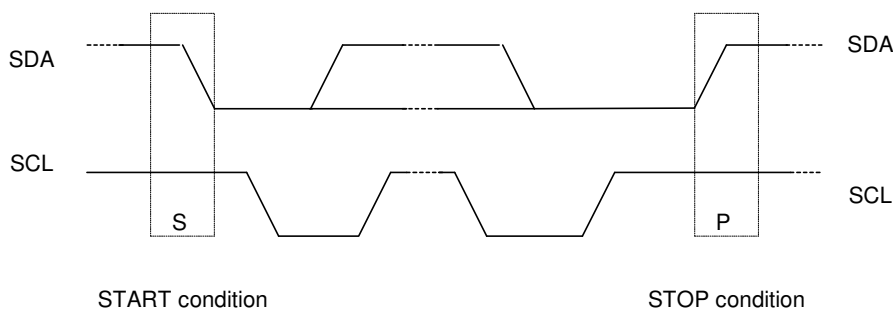

Figure 6 Start and Stop conditions

System configuration

- Transmitter: The device that sends the data to the bus.
- Receiver: The device that receives the data from the bus.
- Master: The device that initiates a transfer generates clock signals and terminates a transfer.
- Slave: The device addressed by a master.
- Multi-Master: More than one master can attempt to control the bus at the same time without corrupting the message
- Arbitration: Procedure to ensure that, if more than one master simultaneously tries to control the bus, only one is allowed to do so and the message is not corrupted.
- Synchronization: Procedure to synchronize the clock signals of two or more devices.

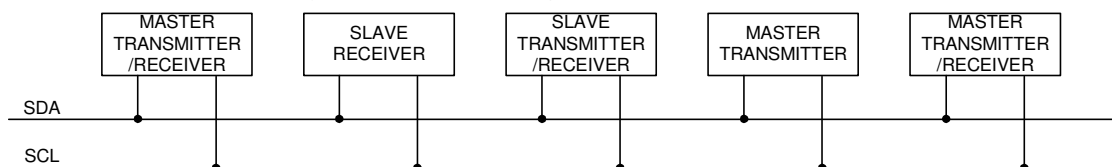

Figure 7 System configuration

Acknowledge

Each byte of eight bits is followed by an acknowledge bit. The acknowledge bit is a HIGH signal put on the bus by the transmitter during which time the master generates an extra acknowledge related clock pulse. A slave receiver which is addressed must generate an acknowledge after the reception of each byte. Also a master receiver must generate an acknowledge after the reception of each byte that has been clocked out of the slave transmitter. The device that acknowledges must pull-down the SDA line during the acknowledge clock pulse, so that the SDA line is stable LOW during the HIGH period of the acknowledge related clock pulse (set-up and hold times must be taken into consideration). A master receiver must signal an end of data to the transmitter by not generating an acknowledge on the last byte that has been clocked out of the slave. In this event the transmitter must leave the data line HIGH to enable the master to generate a stop condition.

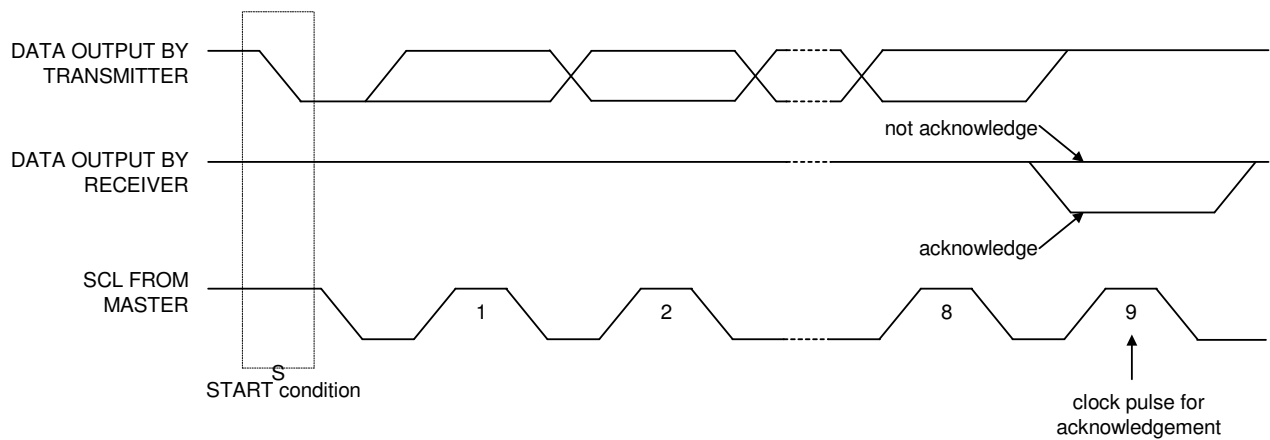

Figure 8 Acknowledge

Protocol

The SH1107 supports both read and write access. The $\overline{R/\overline{W}}$ bit is part of the slave address. Before any data is transmitted on the I²C-bus, the device that should respond is addressed first. Two 7-bit slave addresses (0111100 and 0111101) are reserved for the SH1107. The least significant bit of the slave address is set by connecting the input SA0 to either logic 0(VSS) or 1 (VDD). The I²C-bus protocol is illustrated in Fig.7. The sequence is initiated with a START condition (S) from the I²C-bus master that is followed by the slave address. All slaves with the corresponding address acknowledge in parallel, all the others will ignore the I²C-bus transfer. After acknowledgement, one or more command words follow which define the status of the addressed slaves. A command word consists of a control byte, which defines Co and $\overline{D/\overline{C}}$ (note1), plus a data byte (see Fig.9). The last control byte is tagged with a cleared most significant bit, the continuation bit Co. After a control byte with a cleared Co-bit, only data bytes will follow. The state of the $\overline{D/\overline{C}}$ -bit defines whether the data-byte is interpreted as a command or as RAM-data. The control and data bytes are also acknowledged by all addressed slaves on the bus. After the last control byte, depending on the $\overline{D/\overline{C}}$ bit setting, either a series of display data bytes or command data bytes may follow. If the $\overline{D/\overline{C}}$ bit was set to '1', these display bytes are stored in the display RAM at the address specified by the data pointer. The data pointer is automatically updated and the data is directed to the intended SH1107 device. If the $\overline{D/\overline{C}}$ bit of the last control byte was set to '0', these command bytes will be decoded and the setting of the device will be changed according to the received commands. The acknowledgement after each byte is made only by the addressed slave. At the end of the transmission the I²C-bus master issues a stop condition (P). If the $\overline{R/\overline{W}}$ bit is set to one in the slave-address, the chip will output data immediately after the slave-address according to the $\overline{D/\overline{C}}$ bit, which was sent during the last write access. If no acknowledge is generated by the master after a byte, the driver stops transferring data to the master.

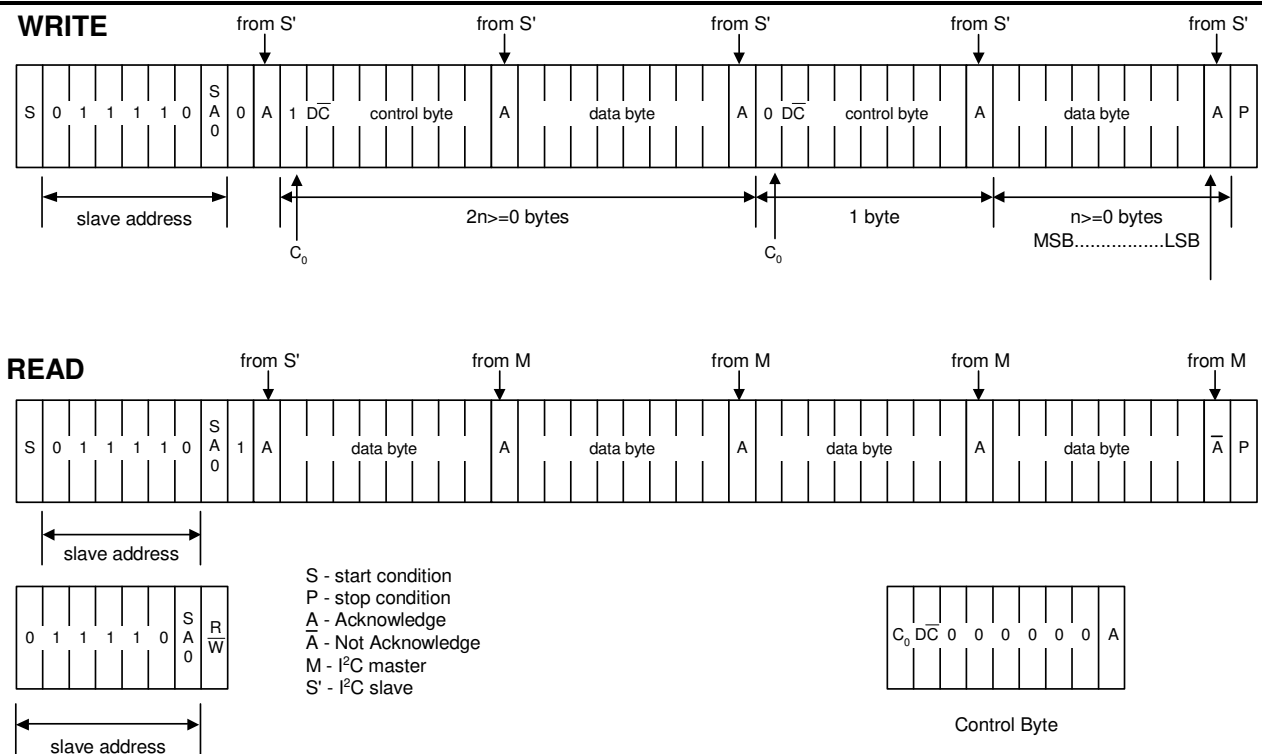

Figure 9 I²C Protocol

Note1:

1. Co = "0" : The last control byte , only data bytes to follow,
Co = "1" : Next two bytes are a data byte and another control byte;
2. D/C = "0" : The data byte is for command operation,
D/C = "1" : The data byte is for RAM operation.

Access to Display Data RAM and Internal Registers

This module determines whether the input data is interpreted as data or command. When A0 = "H", the inputs at D7 - D0 are interpreted as data and be written to display RAM. When A0 = "L", the inputs at D7 - D0 are interpreted as command, they will be decoded and be written to the corresponding command registers.

Display Data RAM

The Display Data RAM is a bit mapped static RAM holding the bit pattern to be displayed. The size of the RAM is 128 X 128 bits. For mechanical flexibility, re-mapping on segment and the direction of common outputs can be selected by software.

The Page Address Circuit

As shown in Figure 10, page address of the display data RAM is specified through the Page Address Set Command. The page address must be specified again when changing pages to perform access in page addressing mode and it is incremented (+1) with each display data read/write command in vertical addressing mode.



The Column Address Circuit

As shown in Figure 10, the display data RAM column address is specified by the Column Address Set command. The specified column address or page address (it depends on the mode of RAM addressing) is incremented (+1) with each display data read/write command. This allows the MPU display data to be accessed continuously. Because the column address is independent of the page address, when moving, for example, from page0 column 7FH to page 1 column 00H in page addressing mode, it is necessary to re-specify both the page address and the column address.

The Display Address Circuit

The display address circuit, as shown in Figure 10, specifies the display address relating to the common output when the contents of the display data RAM are displayed. (This is the COM0 output when the common output mode is normal and the COM127 output for SH1107 when the common output mode is reversed. The display area is a 128-line area for the SH1107 from the first display address. As shown in Table 8, the common driver direction select command can be used to reverse the relationship between the display data RAM display address and the common output.

Table 8

Common Output Scan Direction	COM0	...	COM127
D= "0"	0 (H) →	Display Address	→ 7F (H)
D= "1"	7F (H) ←	Display Address	← 0 (H)



Common output		Page address				Display address	Column	Segment output (ADC=0)
D=0	D=1	D3	D2	D1	D0			
00H	7FH	0	0	0	0	00H	Seg0	
01H	7eH	0	0	0	1	01H	Seg1	
02H	7dH	0	0	1	0	02H	Seg2	
03H	7cH	0	0	1	1	03H	Seg3	
04H	7bH	0	1	0	0	04H	Seg4	
05H	7aH	0	1	0	1	05H	Seg5	
06H	79H	0	1	1	0	06H	Seg6	
07H	78H	0	1	1	1	07H	Seg7	
08H	77H	1	0	0	0	08H	Seg8	
09H	76H	1	0	0	1	09H	Seg9	
0aH	75H	1	0	1	0	0aH	Seg10	
0bH	74H	1	0	1	1	0bH	Seg11	
0cH	73H	1	1	0	0	0cH	Seg12	
0dH	72H	1	1	0	1	0dH	Seg13	
0eH	71H	1	1	1	0	0eH	Seg14	
0fH	70H	1	1	1	1	0fH	Seg15	
...	
7cH	03H					7cH	Seg120	
7dH	02H					7dH	Seg121	
7eH	01H					7eH	Seg122	
7fH	00H					7fH	Seg123	
							Seg124	
							Seg125	
							Seg126	
							Seg127	

Figure 10 (a) RAM map example: ADC=0(POR)



The Oscillator Circuit

This is a RC type oscillator (Figure 11) that produces the display clock. The oscillator circuit is only enabled when CLS = "H". When CLS = "L", the oscillation stops and the display clock is inputted through the CL terminal.

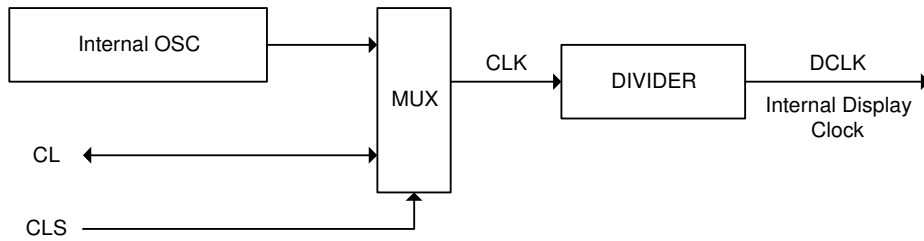

Figure 11



DC-DC Voltage Converter

It is a switching voltage generator circuit, designed for hand held applications. In SH1107, built-in DC-DC voltage converter accompanied with an external application circuit (shown in Figure 12) can generate a high voltage supply VPP from a low voltage supply input AVDD. VPP is the voltage supply to the OLED driver block

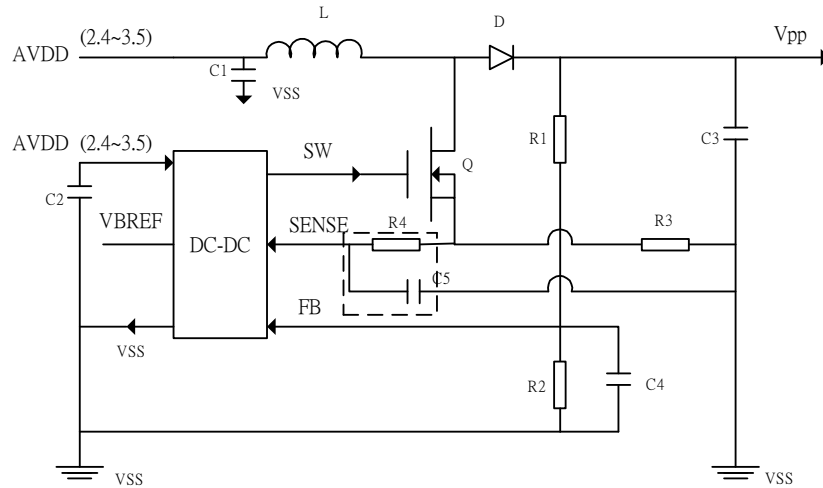

Figure 12

$$V_{PP} = \left(1 + \frac{R_1}{R_2}\right) \times V_{BREF}, (R_2: 80 - 120k\Omega)$$

Note: R4&C5 are optional; they can increase the efficiency of inductance

Current Control and Voltage Control

This block is used to derive the incoming power sources into different levels of internal use voltage and current. VPP and VDD are external power supplies. IREF is a reference current source for segment current drivers, it can change the brightness of the screen and the value depends on the resistance of R_{ref} and Vpp:

When Vpp=15V, contrast = 0xff, the value of resistor R_{ref} can be found as Table 9:

Table 9

IREF	15.625μA	11.25μA	6.25μA
I _{seg} (Max)	500μA	360μA	200μA
R _{ref}	750 K Ω	1M Ω	1.8M Ω

Common Drivers/Segment Drivers

Segment drivers deliver 128 current sources to drive OLED panel. The driving current can be adjusted up to 500μA with 256 steps. Common drivers generate voltage scanning pulses.



Reset Circuit

When the $\overline{\text{RES}}$ input falls to “L”, these reenter their default state. The default settings are shown below:

1. Display is OFF. Common and segment are in high impedance state.
2. 128 X 128 Display mode.
3. Normal segment and display data mapping (SEG0 is mapped to the top line of the display).
4. Shift register data clear in serial interface.
5. Column address counter is set at 0.
6. Contrast control register is set at 80H.
7. Normal common scan direction
8. Internal DC-DC is selected.



Commands

The SH1107 uses a combination of A0, \overline{RD} (E) and \overline{WR} (R/ \overline{W}) signals to identify data bus signals. As the chip analyzes and executes each command using internal timing clock only regardless of external clock, its processing speed is very high and its busy check is usually not required. The 8080 series microprocessor interface enters a read status when a low pulse is input to the \overline{RD} pad and a write status when a low pulse is input to the \overline{WR} pad. The 6800 series microprocessor interface enters a read status when a high pulse is input to the R/ \overline{W} pad and a write status when a low pulse is input to this pad. When a high pulse is input to the E pad, the command is activated. (For timing, see AC Characteristics.). Accordingly, in the command explanation and command table, \overline{RD} (E) becomes 1(HIGH) when the 6800 series microprocessor interface reads status of display data. This is an only different point from the 8080 series microprocessor interface.

Taking the 8080 series, microprocessor interface as an example command will explain below. When the serial interface is selected, input data starting from D7 in sequence.

Command Set

1. Set Lower Column Address: (00H - 0FH)

2. Set Higher Column Address: (10H - 17H)

Specify column address of display RAM. Divide the column address into 4 higher bits and 4 lower bits. Set each of them into successions. When the microprocessor repeats to access to the display RAM, the column address counter is incremented during each access until address 127 is accessed (In page addressing mode).The page address is not changed during this time.

	A0	\overline{RD} (E)	\overline{WR} (R/ \overline{W})	D7	D6	D5	D4	D3	D2	D1	D0
High bits	0	1	0	0	0	0	1	0	A6	A5	A4
Low bits	0	1	0	0	0	0	0	A3	A2	A1	A0

A6	A5	A4	A3	A2	A1	A0	Display address
0	0	0	0	0	0	0	0(POR)
0	0	0	0	0	0	1	1
:							:
1	1	1	1	1	1	1	127

Note: Don't use any commands not mentioned above.



3. Set Memory addressing mode (20H - 21H)

There are two different memory addressing modes in SH1107: page addressing mode and vertical addressing mode. This command sets the way of memory addressing into one of the above two modes, "COL" means column.

A0	\overline{RD} (E)	\overline{WR} (R/ \overline{W})	D7	D6	D5	D4	D3	D2	D1	D0
0	1	0	0	0	1	0	0	0	0	D

■ Page addressing mode (20H) (POR)

In page addressing mode, after the display RAM is read/ written, the column address is increased automatically by 1. If the column address reaches column end address, the column address is reset to column start address and page address is not changed. Users have to set the new page and column addresses in order to access the next page RAM content. When the Segment is remapped, the direction of both page and byte are reversed. The sequence of movement of the page and column address for page addressing mode is shown in Figure 13-1 and Figure 13-2.

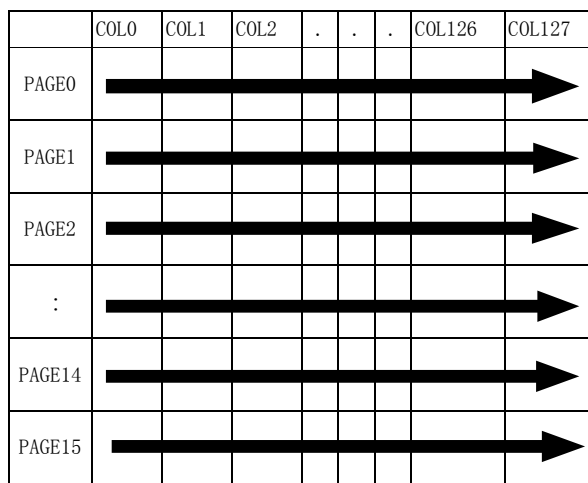

Figure13-1(a)

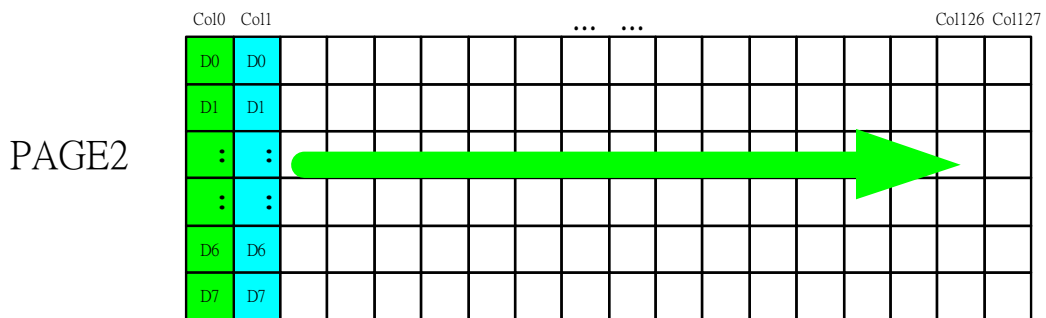

Figure13-1(b)

Figure13-1 page addressing mode (Seg remap=0)

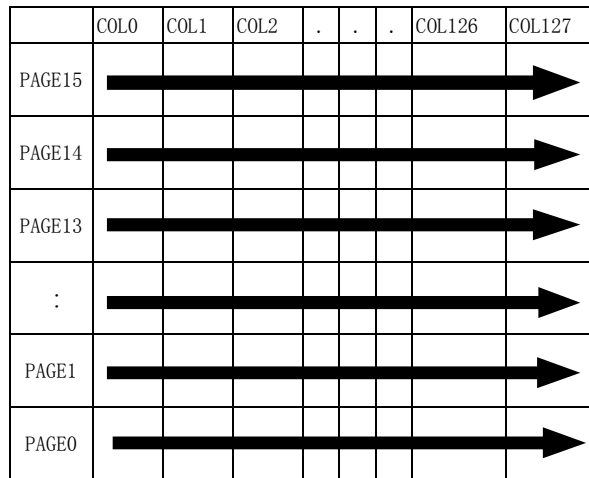

Figure13-2(a)

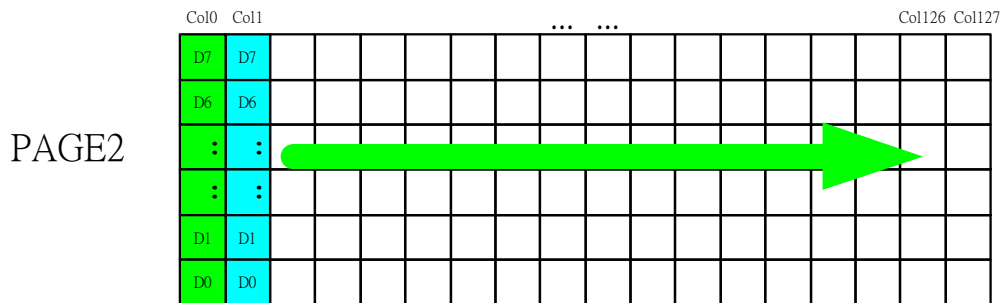

Figure13-2(b)

Figure13-2 page addressing mode (Seg remap=1)



■ Vertical addressing mode: (21H)

In vertical addressing mode, after the display RAM is read/ written, the page address is increased automatically by 1. If the page address reaches the page end address, the page address is reset to page start address and column address is not changed. Users have to set the new page and column addresses in order to access the next column. When the Segment is remapped, the direction of both page and byte are reversed. The sequence of movement of the page and column address for vertical addressing mode is shown in Figure 13-3 and Figure 13-4.

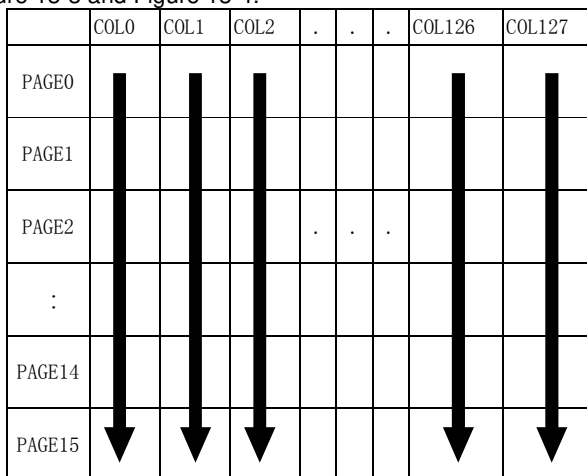

Figure 13-3 (a)

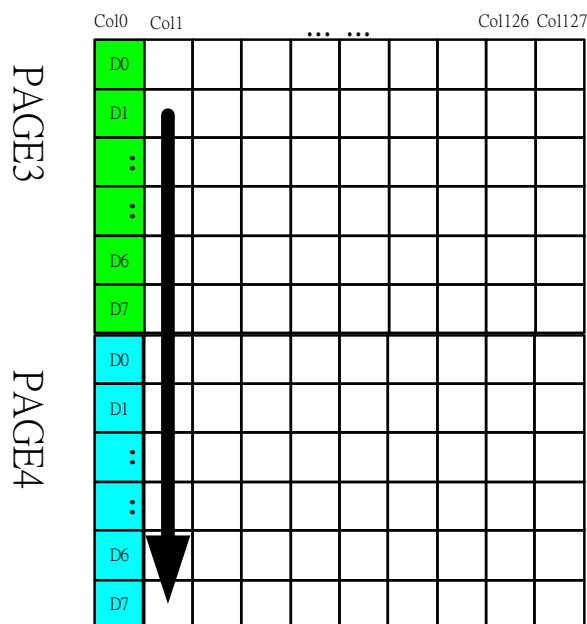

Figure13-3 (b)

Figure 13-3 Vertical addressing mode (Seg remap=0)

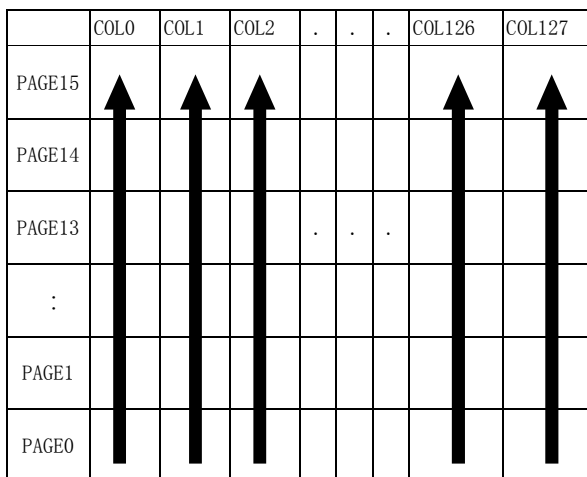

Figure13-4 (a)

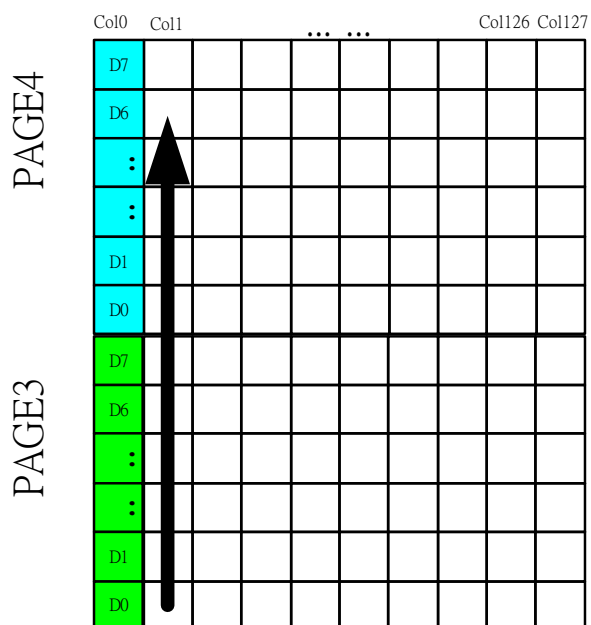

Figure13-4 (b)

13-4 Vertical addressing mode (Seg remap=1)



4. Set Contrast Control Register: (Double Bytes Command)

This command is to set contrast setting of the display. The chip has 256 contrast steps from 00 to FF. The segment output current increases as the contrast step value increases.

Segment output current setting: $I_{SEG} = \alpha/256 \times I_{REF} \times \text{scale factor}$

Where: α is contrast step; I_{REF} is reference current equals 15.625 μ A; Scale factor = 32

■ The Contrast Control Mode Set: (81H)

When this command is input, the contrast data register set command becomes enabled. Once the contrast control mode has been set, no other command except for the contrast data register command can be used. Once the contrast data set command has been used to set data into the register, then the contrast control mode is released.

A0	\overline{RD} (E)	\overline{WR} (R/ \overline{W})	D7	D6	D5	D4	D3	D2	D1	D0
0	1	0	1	0	0	0	0	0	0	1

■ Contrast Data Register Set: (00H - FFH)

By using this command to set eight bits of data to the contrast data register; the OLED segment output assumes one of the 256 current levels.

When this command is input, the contrast control mode is released after the contrast data register has been set.

A0	\overline{E} (RD)	$\overline{R/W}$ (WR)	D7	D6	D5	D4	D3	D2	D1	D0	I _{SEG}
0	1	0	0	0	0	0	0	0	0	0	Small
0	1	0	0	0	0	0	0	0	0	1	
0	1	0	0	0	0	0	0	0	1	0	
0	1	0					:				:
0	1	0	1	0	0	0	0	0	0	0	POR
0	1	0					:				:
0	1	0	1	1	1	1	1	1	1	0	
0	1	0	1	1	1	1	1	1	1	1	Large



5. Set Segment Re-map: (A0H - A1H)

Change the relationship between RAM page address and segment driver. The order of segment driver output pads can be reversed by software. This allows flexible IC layout during OLED module assembly. For details, refer to the page address section of Figure 10. When display data is written or read, the column address or page address (depends on the memory addressing mode) is incremented by 1 as shown in Figure 2.

A0	\overline{RD} (E)	\overline{WR} (R/W)	D7	D6	D5	D4	D3	D2	D1	D0
0	1	0	1	0	1	0	0	0	0	ADC

When ADC = "L", the down rotates (normal direction). (POR)

When ADC = "H", the up rotates (reverse direction).

The display examples of Segment Re-map command are showed in Figure 14

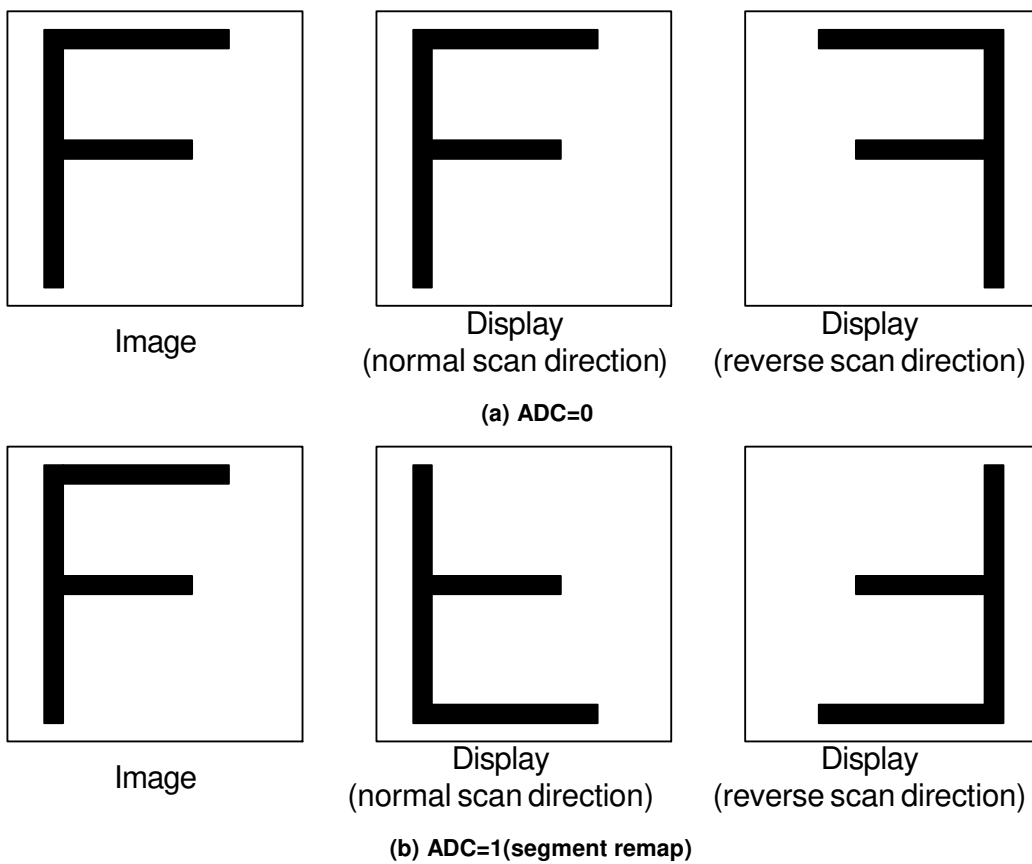

Figure 14 the display example of Set Segment Re-map and common scan direction command



6. Set Multiplex Ration: (Double Bytes Command)

This command switches default 128 multiplex modes to any multiplex ratio from 1 to 128. The output pads COM0-COM127 will be switched to corresponding common signal.

■ Multiplex Ration Mode Set: (A8H)

A0	\overline{RD} (E)	\overline{WR} (R/ \overline{W})	D7	D6	D5	D4	D3	D2	D1	D0
0	1	0	1	0	1	0	1	0	0	0

■ Multiplex Ration Data Set: (00H - 7FH)

A0	\overline{RD} (E)	\overline{WR} (R/ \overline{W})	D7	D6	D5	D4	D3	D2	D1	D0	Multiplex Ratio
0	1	0	*	0	0	0	0	0	0	0	1
0	1	0	*	0	0	0	0	0	0	1	2
0	1	0	*	0	0	0	0	0	1	0	3
0	1	0					:				:
0	1	0	*	1	1	0	1	1	1	0	127
0	1	0	*	1	1	1	1	1	1	1	128 (POR)

7. Set Entire Display OFF/ON: (A4H - A5H)

Forcibly turns the entire display on regardless of the contents of the display data RAM. At this time, the contents of the display data RAM are held.

This command has priority over the normal/reverse display command.

A0	\overline{RD} (E)	\overline{WR} (R/ \overline{W})	D7	D6	D5	D4	D3	D2	D1	D0
0	1	0	1	0	1	0	0	1	0	D

When D = "L", the normal display status is provided. (POR)

When D = "H", the entire display ON status is provided.



8. Set Normal/Reverse Display: (A6H -A7H)

Reverse the display ON/OFF status without rewriting the contents of the display data RAM.

A0	\overline{RD} (E)	\overline{WR} (R/ \overline{W})	D7	D6	D5	D4	D3	D2	D1	D0
0	1	0	1	0	1	0	0	1	1	D

When D = "L", the RAM data is high, being OLED ON potential (normal display). (POR)

When D = "H", the RAM data is low, being OLED ON potential (reverse display)

The display example of Entire display off/on and normal/reverse command are showed in Figure 15

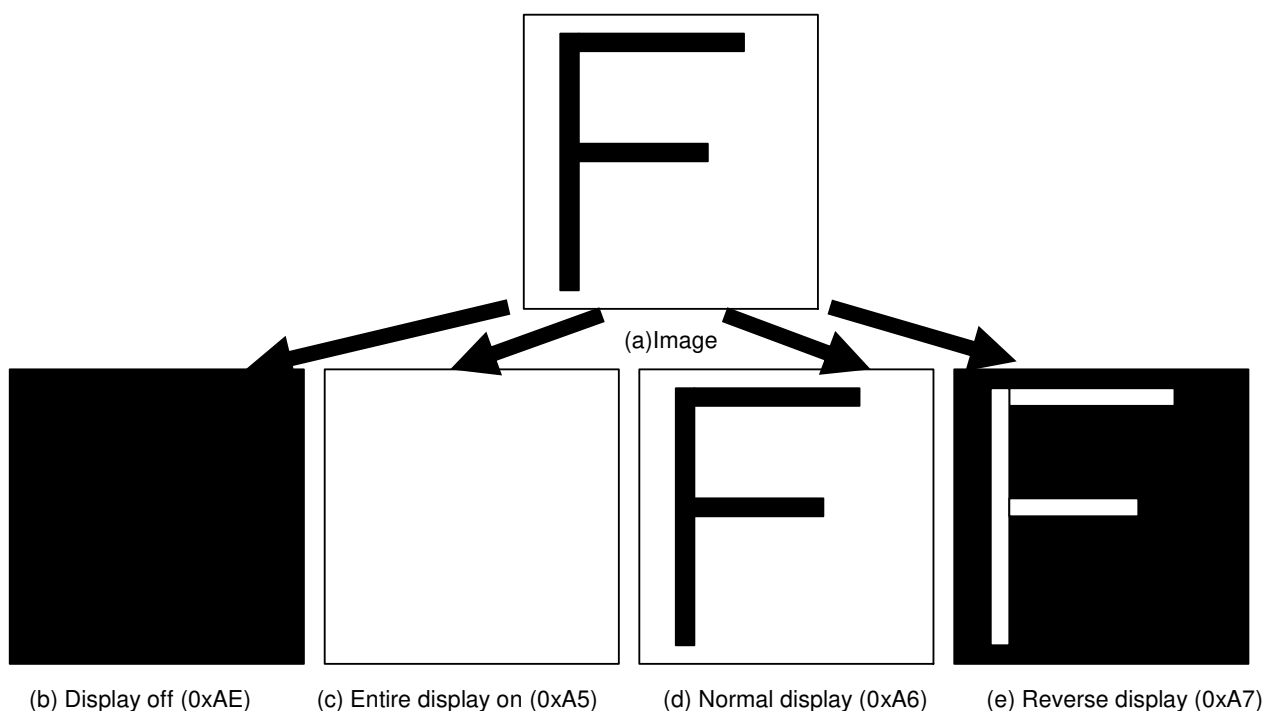

Figure 15: display example of entire display on and normal/reverse



9. Set Display Offset: (Double Bytes Command)

This is a double byte command. The next command specifies the mapping of display start line to one of COM0-127. For example, if COM0 is the display start line, the value is 00H; while if COM16 is the display start line, then the value should be 10H.

Display Offset Mode Set: (D3H)

A0	\overline{RD} (E)	\overline{WR} (R/ \overline{W})	D7	D6	D5	D4	D3	D2	D1	D0
0	1	0	1	1	0	1	0	0	1	1

■ Display Offset Data Set: (00H – 7FH)

A0	\overline{RD} (E)	\overline{WR} (R/ \overline{W})	D7	D6	D5	D4	D3	D2	D1	D0	COMx
0	1	0	*	0	0	0	0	0	0	0	0 (POR)
0	1	0	*	0	0	0	0	0	0	1	1
0	1	0	*	0	0	0	0	0	1	0	2
0	1	0					:				:
0	1	0	*	1	1	0	1	1	1	0	126
0	1	0	*	1	1	1	1	1	1	1	127

Note: "*" stands for "Don't care"

10. Set DC-DC Setting: (Double Bytes Command)

This command is to control the DC-DC voltage converter status and the switch frequency. Issuing this command then display ON command will turn on the converter. The panel display must be off while issuing this command.

■ DC-DC Control Mode Set: (ADH)

A0	\overline{RD} (E)	\overline{WR} (R/ \overline{W})	D7	D6	D5	D4	D3	D2	D1	D0
0	1	0	1	0	1	0	1	1	0	1

■ DC-DC ON/OFF Mode Set: (8AH - 8BH)

A0	\overline{RD} (E)	\overline{WR} (R/ \overline{W})	D7	D6	D5	D4	D3	D2	D1	D0
0	1	0	1	0	0	0	F2	F1	F0	D

When D = "L", DC-DC is disable.

When D = "H", DC-DC will be turned on when display on. (POR)

DC-DC STATUS	DISPLAY ON/OFF STATUS	Description
0	0	Sleep mode
0	1	External VPP must be used.
1	0	Sleep mode
1	1	Built-in DC-DC is used, Normal Display

F2	F1	F0	Switch Frequency
0	0	0	0.6SF (POR)
0	0	1	0.7SF
0	1	0	0.8SF
0	1	1	0.9SF
1	0	0	1.0SF
1	0	1	1.1SF
1	1	0	1.2SF
1	1	1	1.3SF

500KHz-25%<SF<500KHz+35%



11. Display OFF/ON: (AEH - AFH)

Alternatively turns the display on and off.

A0	\overline{RD} (E)	\overline{WR} (R/ \overline{W})	D7	D6	D5	D4	D3	D2	D1	D0
0	1	0	1	0	1	0	1	1	1	D

When D = "L", Display OFF OLED. (POR)

When D = "H", Display ON OLED.

When the display OFF command is executed, power saver mode will be entered.

Sleep mode:

This mode stops every operation of the OLED display system, and can reduce current consumption nearly to a static current value if no access is made from the microprocessor. The internal status in the sleep mode is as follows:

- (1) Stops the oscillator circuit and DC-DC circuit.
- (2) Stops the OLED drive and outputs Hz as the segment/common driver output.
- (3) Holds the display data and operation mode provided before the start of the sleep mode.
- (4) The MPU can access to the built-in display RAM.

12. Set Page Address: (B0H - BFH)

Specify page address to load display RAM data to page address register. Any RAM data bit can be accessed when its page address and column address are specified. The display remains unchanged even when the page address is changed.

A0	\overline{RD} (E)	\overline{WR} (R/ \overline{W})	D7	D6	D5	D4	D3	D2	D1	D0
0	1	0	1	0	1	1	A3	A2	A1	A0

A3	A2	A1	A0	Page Address
0	0	0	0	0(POR)
0	0	0	1	1
0	0	1	0	2
.
.
.
1	1	0	1	13
1	1	1	0	14
1	1	1	1	15

Note: Don't use any commands not mentioned above for user.



13. Set Common Output Scan Direction: (C0H - C8H)

This command sets the scan direction of the common output allowing layout flexibility in OLED module design. In addition, the display will have immediate effect once this command is issued. That is, if this command is sent during normal display, the graphic display will be vertically flipped.

A0	\overline{RD} (E)	\overline{WR} (R/ \overline{W})	D7	D6	D5	D4	D3	D2	D1	D0
0	1	0	1	1	0	0	D	*	*	*

When D = "L", Scan from COM0 to COM [N -1]. (POR)

When D = "H", Scan from COM [N -1] to COM0.



14. Set Display Clock Divide Ratio/Oscillator Frequency: (Double Bytes Command)

This command is used to set the frequency of the internal display clocks (DCLKs). It is defined as the divide ratio (Value from 1 to 16) used to divide the oscillator frequency. POR is 1. Frame frequency is determined by divide ratio, number of display clocks per row and oscillator frequency.

- Divide Ratio/Oscillator Frequency Mode Set: (D5H)

A0	\overline{RD} (E)	\overline{WR} (R/ \overline{W})	D7	D6	D5	D4	D3	D2	D1	D0
0	1	0	1	1	0	1	0	1	0	1

- Divide Ratio/Oscillator Frequency Data Set: (00H - FFH)

A0	$\frac{E}{\overline{RD}}$	$\frac{R/\overline{W}}{\overline{WR}}$	D7	D6	D5	D4	D3	D2	D1	D0
0	1	0	A7	A6	A5	A4	A3	A2	A1	A0

A3 - A0 defines the divide ration of the display clocks (DCLK). Divide Ration = A[3:0] + 1.

A3	A2	A1	A0	Divide Ration
0	0	0	0	1 (POR)
		:		:
1	1	1	1	16

A7 - A4 sets the oscillator frequency. Oscillator frequency increases with the value of A[7:4] and vice versa.

A7	A6	A5	A4	Oscillator Frequency of f_{osc}
0	0	0	0	-25%
0	0	0	1	-20%
0	0	1	0	-15%
0	0	1	1	-10%
0	1	0	0	-5%
0	1	0	1	f_{osc} (POR)
0	1	1	0	+5%
0	1	1	1	+10%
1	0	0	0	+15%
1	0	0	1	+20%
1	0	1	0	+25%
1	0	1	1	+30%
1	1	0	0	+35%
1	1	0	1	+40%
1	1	1	0	+45%
1	1	1	1	+50%



15. Set Dis-charge/Pre-charge Period: (Double Bytes Command)

This command is used to set the duration of the pre-charge period. The interval is counted in number of DCLK. POR is 2 DCLKs.

- Pre-charge Period Mode Set: (D9H)

A0	\overline{RD} (E)	\overline{WR} (R/ \overline{W})	D7	D6	D5	D4	D3	D2	D1	D0
0	1	0	1	1	0	1	1	0	0	1

- Dis-charge/Pre-charge Period Data Set: (00H - FFH)

A0	\overline{RD} (E)	\overline{WR} (R/ \overline{W})	D7	D6	D5	D4	D3	D2	D1	D0
0	1	0	A7	A6	A5	A4	A3	A2	A1	A0

Pre-charge Period Adjust: (A3 - A0)

A3	A2	A1	A0	Pre-charge Period
0	0	0	0	Note
0	0	0	1	1 DCLKs
0	0	1	0	2 DCLKs (POR)
		:		:
1	1	1	0	14 DCLKs
1	1	1	1	15 DCLKs

Dis-charge Period Adjust: (A7 - A4)

A7	A6	A5	A4	Dis-charge Period
0	0	0	0	INVALID
0	0	0	1	1 DCLKs
0	0	1	0	2 DCLKs (POR)
		:		:
1	1	1	0	14 DCLKs
1	1	1	1	15 DCLKs

Note:

When set A[3:0] =0, the period for display will increase 2 DCLKs. And there is no pre-charge period so that it will save power consumption.



16. Set VCOM Deselect Level: (Double Bytes Command)

This command is to set the common pad output voltage level at deselect stage.

- VCOM Deselect Level Mode Set: (DBH)

A0	\overline{RD} (E)	\overline{WR} (R/ \overline{W})	D7	D6	D5	D4	D3	D2	D1	D0
0	1	0	1	1	0	1	1	0	1	1

- VCOM Deselect Level Data Set: (00H - FFH)

A0	\overline{RD} (E)	\overline{WR} (R/ \overline{W})	D7	D6	D5	D4	D3	D2	D1	D0
0	1	0	A7	A6	A5	A4	A3	A2	A1	A0

$$V_{COMH} = \beta_1 \times V_{REF} = (0.430 + A[7:0] \times 0.006415) \times V_{REF}$$

A[7:0]	β_1	A[7:0]	β_1
00H	0.430	20H	0.635
01H	0.436	21H	0.642
02H	0.442	22H	0.648
03H	0.449	23H	0.654
04H	0.456	24H	0.661
05H	0.462	25H	0.667
06H	0.468	26H	0.674
07H	0.475	27H	0.680
08H	0.481	28H	0.687
09H	0.488	29H	0.693
0AH	0.494	2AH	0.699
0BH	0.501	2BH	0.706
0CH	0.507	2CH	0.712
0DH	0.513	2DH	0.719
0EH	0.520	2EH	0.725
0FH	0.526	2FH	0.731
10H	0.533	30H	0.738
11H	0.539	31H	0.744
12H	0.525	32H	0.751
13H	0.552	33H	0.757
14H	0.558	34H	0.764
15H	0.565	35H	0.770 (POR)
16H	0.571	36H	0.776
17H	0.578	37H	0.783
18H	0.584	38H	0.789
19H	0.590	39H	0.796
1AH	0.596	3AH	0.802
1BH	0.603	3BH	0.808
1CH	0.610	3CH	0.815
1DH	0.616	3DH	0.821
1EH	0.622	3EH	0.828
1FH	0.629	3FH	0.834
40H - FFH	1		

15.—16. Blank



17. Set Display Start Line: (Double Bytes Command)

Specify Column address to determine the initial display line or COM0. The RAM display data becomes the top line of OLED screen. It is followed by the higher number of lines in ascending order, corresponding to the duty cycle. When this command changes the Column address, the smooth scrolling or page change takes place.

■ The Display Start line Mode Set: (DCH)

A0	\overline{RD} (E)	\overline{WR} (R/ \overline{W})	D7	D6	D5	D4	D3	D2	D1	D0
0	1	0	1	1	0	1	1	1	0	0

■ The Display Start line Register Set: (00H – 7FH)

A0	\overline{RD} (E)	\overline{WR} (R/ \overline{W})	D7	D6	D5	D4	D3	D2	D1	D0	Column address
0	1	0	*	0	0	0	0	0	0	0	0(POR)
0	1	0	*	0	0	0	0	0	0	1	1
0	1	0	*	0	0	0	0	0	1	0	2
0	1	0	*				:				:
0	1	0	*								:
0	1	0	*				:				:
0	1	0	*	1	0	1	1	1	1	0	7E
0	1	0	*	1	0	1	1	1	1	1	7F



18. Read-Modify-Write: (E0H)

A pair of Read-Modify-Write and End commands must always be used. In page addressing mode, once read-modify-write is issued, column address is not incremental by read display data command but incremental by write display data command only. In vertical addressing mode, once read-modify-write is issued, page address is not incremental by read display data command but incremental by write display data command only. It continues until End command is issued. When the End is issued, column address or page address (it depends on the addressing mode) returns to the address when read-modify-write is issued. This can reduce the microprocessor load when data of a specific display area is repeatedly changed during cursor blinking or others.

A0	\overline{RD} (E)	\overline{WR} (R/ \overline{W})	D7	D6	D5	D4	D3	D2	D1	D0
0	1	0	1	1	1	0	0	0	0	0

Cursor display sequence:

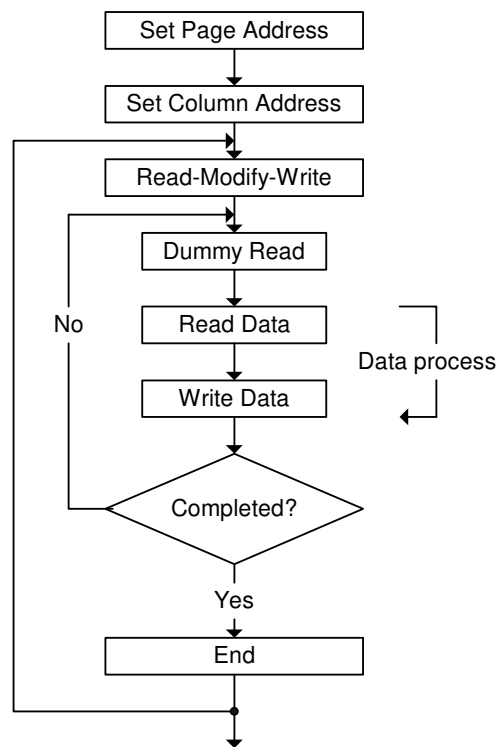

Figure 16



19. End: (EEH)

Cancel Read-Modify-Write mode and return column address or page address (it depends on the RAM addressing mode) to the original address (when Read-Modify-Write is issued.)

A0	$\overline{RD}(E)$	$\overline{WR}(R/\overline{W})$	D7	D6	D5	D4	D3	D2	D1	D0
0	1	0	1	1	1	0	1	1	1	0

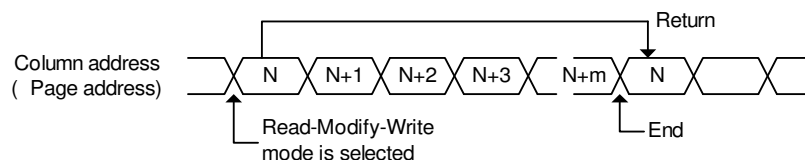

Figure 17

20. NOP: (E3H)

No Operation Command.

A0	$\overline{RD}(E)$	$\overline{WR}(R/\overline{W})$	D7	D6	D5	D4	D3	D2	D1	D0
0	1	0	1	1	1	0	0	0	1	1

21. Write Display Data

Write 8-bit data in display RAM. As the column address is incremental by 1 automatically after each write, the microprocessor can continue to write data of multiple words.

A0	$\overline{RD}(E)$	$\overline{WR}(R/\overline{W})$	D7	D6	D5	D4	D3	D2	D1	D0
1	1	0	Write RAM data							

22. Read ID

A0	$\overline{RD}(E)$	$\overline{WR}(R/\overline{W})$	D7	D6	D5	D4	D3	D2	D1	D0
0	0	1	BUSY	ON/OFF	ID					

BUSY: When high, the SH1107 is busy due to internal operation or reset. Any command is rejected until BUSY goes low. The busy check is not required if enough time is provided for each cycle.

ON/OFF: Indicates whether the display is on or off. When it goes low, the display turns on. When it goes high, the display turns off. This is the opposite of Display ON/OFF command.

ID : These bits contain the information of the chip. They output bits 000111(it means 07).

23. Read Display Data

Read 8-bit data from display RAM area specified by column address and page address. As the column address or page address (depends on the mode of memory addressing) is increment by 1 automatically after each write, the microprocessor can continue to read data of multiple words. A single dummy read is required immediately after column address being setup. Refer to the display RAM section of FUNCTIONAL DESCRIPTION for details. Note that no display data can be read via the serial interface.

A0	$\overline{RD}(E)$	$\overline{WR}(R/\overline{W})$	D7	D6	D5	D4	D3	D2	D1	D0
1	0	1	Read RAM data							



Command Table

Command	Code											Function	
	A0	RD	WR	D7	D6	D5	D4	D3	D2	D1	D0		
1. Set Column Address 4 lower bits	0	1	0	0	0	0	0	Lower column address				0	Sets 4 lower bits of column address of display RAM in register. (POR = 00H)
2. Set Column Address 4 higher bits	0	1	0	0	0	0	1	0	Higher column address			0	Sets 4 higher bits of column address of display RAM in register. (POR = 10H)
3. Set memory addressing mode	0	1	0	0	0	1	0	0	0	0	D	D = 1, Vertical Addressing Mode D = 0, Page Addressing Mode (POR=20H)	
4. The Contrast Control Mode Set	0	1	0	1	0	0	0	0	0	0	1	This command is to set Contrast Setting of the display. The chip has 256 contrast steps from 00 to FF. (POR = 80H)	
Contrast Data Register Set	0	1	0	Contrast Data									
5. Set Segment Re-map (ADC)	0	1	0	1	0	1	0	0	0	0	ADC	The down (0) or up (1) rotation. (POR = A0H)	
6. Set Multiplex Ration	0	1	0	1	0	1	0	1	0	0	0	This command switches multiplex mode to any multiplex ratio from 1 to 128. (POR = 7FH)	
	0	1	0	-	Multiplex Ratio								
7. Set Entire Display OFF/ON	0	1	0	1	0	1	0	0	1	0	D	Selects normal display (0) or Entire Display ON (1). (POR = A4H)	
8. Set Normal/ Reverse Display	0	1	0	1	0	1	0	0	1	1	D	Normal indication (0) when low, but reverse indication (1) when high. (POR = A6H)	
9. Set display offset	0	1	0	1	1	0	1	0	0	1	1	This is a double byte command that specifies the mapping of display start line to one of COM0 -127. (POR = 00H)	
	0	1	0	-	COMx								
10. DC-DC Control Mode Set DC-DC Setting Mode Set	0	1	0	1	0	1	0	1	1	0	1	This command is to control the DC-DC voltage DC-DC will be turned on when display on converter (1) or DC-DC OFF (0). (POR = 81H)	
	0	1	0	1	0	0	0	F2	F1	F0	D		



Command Table (Continued)

Command	Code											Function
	A0	RD	WR	D7	D6	D5	D4	D3	D2	D1	D0	
11. Display OFF/ON	0	1	0	1	0	1	0	1	1	1	D	Turns on OLED panel (1) or turns off (0). (POR = AEH)
12. Set Page Address	0	1	0	1	0	1	1	Page Address				Specifies page address to load display RAM data to page address register. (POR = B0H)
13. Set Common Output Scan Direction	0	1	0	1	1	0	0	D	*	*	*	Scan from COM0 to COM [N - 1] (0) or Scan from COM [N - 1] to COM0 (1). (POR = C0H)
14. Set Display Divide Ratio/Oscillator Frequency Mode Set	0	1	0	1	1	0	1	0	1	0	1	This command is used to set the frequency of the internal display clocks. (POR = 50H)
Divide Ratio/Oscillator Frequency Data Set	0	1	0	Oscillator Frequency				Divide Ratio				
15. Dis-charge / Pre-charge Period Mode Set	0	1	0	1	1	0	1	1	0	0	1	This command is used to set the duration of the dis-charge and pre-charge period. (POR = 22H)
Dis-charge /Pre-charge Period Data Set	0	1	0	Dis-charge Period				Pre-charge Period				
16. VCOM Deselect Level Mode Set	0	1	0	1	1	0	1	1	0	1	1	This command is to set the common pad output voltage level at deselect stage. (POR = 35H)
VCOM Deselect Level Data Set	0	1	0	VCOM = ($\beta_1 \times V_{REF}$)								
17. Set Display Start Line	0	1	0	1	1	0	1	1	1	0	0	Specify RAM display line for COM0.
	0	1	0	-	Start line							
18. Read-Modify-Write	0	1	0	1	1	1	0	0	0	0	0	Read-Modify-Write start.
19. End	0	1	0	1	1	1	0	1	1	1	0	Read-Modify-Write end.
20. NOP	0	1	0	1	1	1	0	0	0	1	1	Non-Operation Command
21. Write Display Data	1	1	0	Write RAM data								
22. Read ID	0	0	1	BUSY	ON/OFF	ID						
23. Read Display Data	1	0	1	Read RAM data								

Note: Do not use any other command, or the system malfunction may result.



1. Power On/Off and Initialization

1.1. Built-in DC-DC pump power is being used immediately after turning on the power:

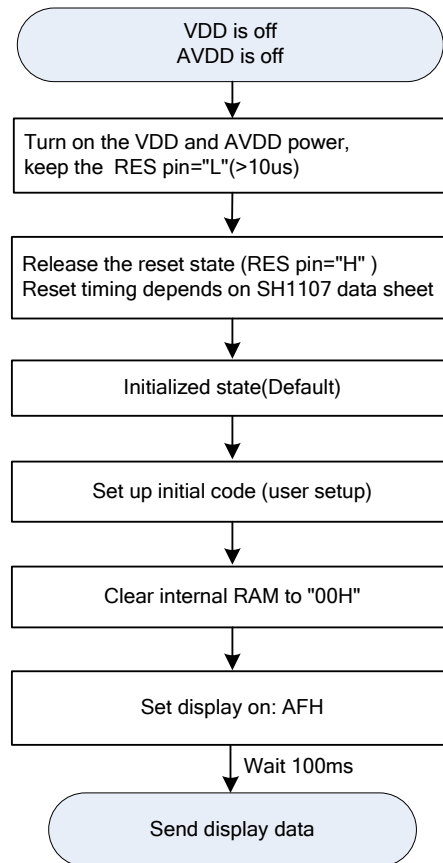

Power on sequence:

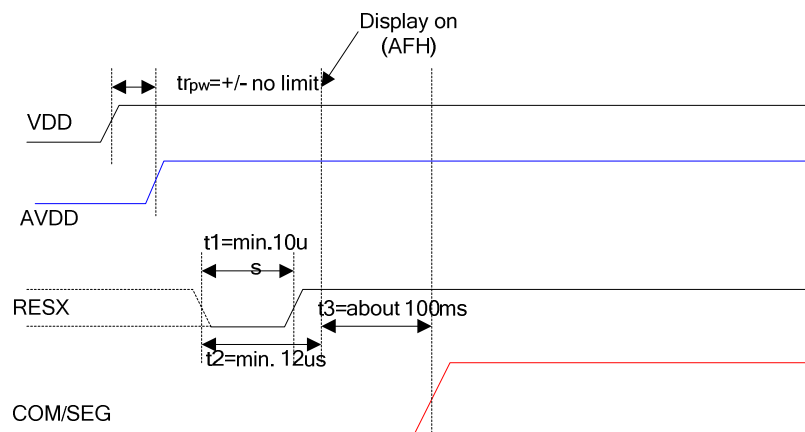



1.2. External power is being used immediately after turning on the power:

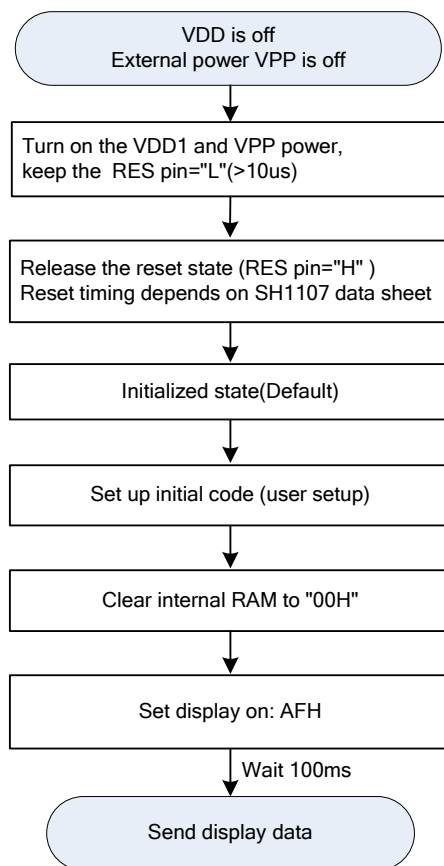

Power on sequence:

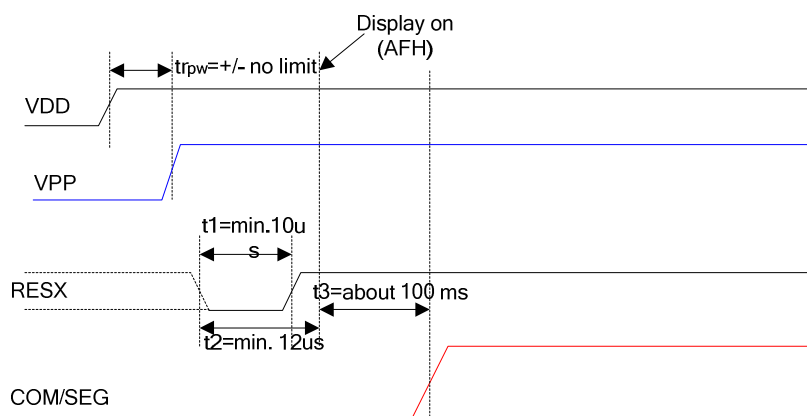



1.3 Power Off

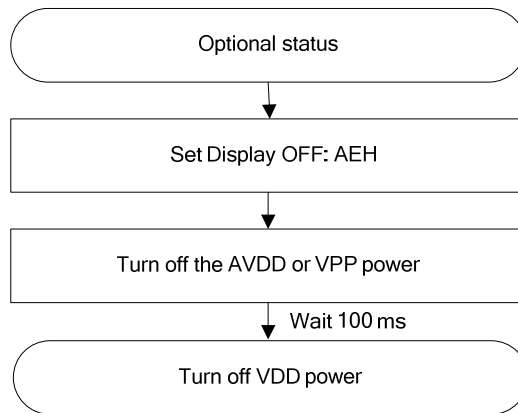

Power off sequence:

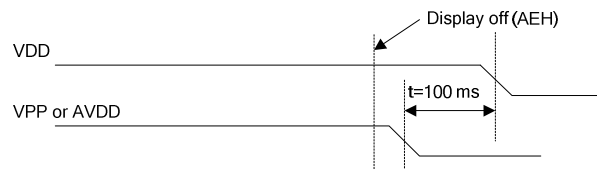

Note: There will be no damages to the display module if the power sequences are not met.



Absolute Maximum Rating*

DC Supply Voltage (VDD) -0.3V to +3.6V
 DC Supply Voltage (VPP) -0.3V to +17V
 Input Voltage -0.3V to VDD + 0.3V
 Operating Ambient Temperature -40°C to +85°C
 Storage Temperature -55°C to +125°C

***Comments**

Stresses above those listed under "Absolute Maximum Ratings" may cause permanent damage to this device. These are stress ratings only. Functional operation of this device under these or any other conditions above those indicated in the operational sections of this specification is not implied or intended. Exposure to the absolute maximum rating conditions for extended periods may affect device reliability.

Electrical Characteristics

DC Characteristics (VSS = 0V, VDD = 1.65 - 3.5V AVDD=2.4-3.5V, TA =+25°C, unless otherwise specified)

Symbol	Parameter	Min.	Typ.	Max.	Unit	Condition
VDD	Operating voltage	1.65	-	3.5	V	
AVDD	DC-DC voltage	2.4	3.0	3.5	V	
VPP	OLED Operating voltage	7	15	16.5	V	
VBREF	Internal voltage reference	1.15	1.20	1.25	V	
IDD1	Dynamic current consumption 1 (in VDD)	-	110	160	μA	VDD = 3V, AVDD=3V, IREF = -15.625μA, Contrast α = 256, Bulid-in DC-DC OFF, Display ON, display data = All ON, No panel attached.
IDD2	Dynamic current consumption 2 (in AVDD)	-	190	285	μA	VDD=3V, AVDD=3V, IREF = -15.625μA, Contrast α = 256, Bulid-in DC-DC ON, VPP=15V, Display ON, display data = All ON, No panel attached.
Ipp	OLED dynamic current consumption	-	1	1.27	mA	VDD = 3V, AVDD =3V ,VPP = 15V, IREF = -15.625μA, Contrast α = 256, Display ON, Display data = All ON, No panel attached
ISP	Sleep mode current consumption in VDD & AVDD	-	0.01	5	μA	During sleep, TA = +25°C, VDD = 3V,AVDD=3V
	Sleep mode current consumption in VPP	-	0.01	5	μA	During sleep, TA = +25°C, VPP = 15V (External)
ISEG	Segment output current	-	-500	-	μA	VDD = 3V, VPP = 15V, IREF = -15.625μA, RLOAD = 20kΩ, Display ON. Contrast α = 256.
		-	-343.75	-	μA	VDD = 3V, VPP = 15V, IREF = -15.625μA, RLOAD = 20kΩ, Display ON. Contrast α = 176.
		-	-187.5	-	μA	VDD = 3V, VPP = 15V, IREF = -15.625μA, RLOAD = 20kΩ, Display ON. Contrast α = 96.
		-	-31.25	-	μA	VDD = 3V, VPP = 15V, IREF = -15.625μA, RLOAD = 20kΩ, Display ON. Contrast α = 16
ΔISEG1	Segment output current uniformity	-	-	±3	%	ΔISEG1 = (ISEG - IMID)/IMID X 100% IMID = (IMAX + IMIN)/2 ISEG [0:131] at contrast α = 256.
ΔISEG2	Adjacent segment output current uniformity	-	-	±2	%	ΔISEG2 = (ISEG [N] - ISEG [N+1])/(ISEG [N] + ISEG [N+1]) X 100% ISEG [0:131] at contrast α = 256.



DC Characteristics (Continued)

Symbol	Parameter	Min.	Typ.	Max.	Unit	Condition
V _{IHC}	High-level input voltage	0.8 X V _{DD}	-	V _{DD}	V	A0, D0 - D7, \overline{RD} (E), \overline{WR} (R/ \overline{W}), \overline{CS} , CLS, CL, IM0~2 and \overline{RES} .
V _{ILC}	Low-level input voltage	V _{SS}	-	0.2 X V _{DD}	V	
V _{OHC}	High-level output voltage	0.8 X V _{DD}	-	V _{DD}	V	I _{OH} = -0.5mA (D0 - D7, and CL).
V _{OLC}	Low -level output voltage	V _{SS}	-	0.2 X V _{DD}	V	I _{OL} = 0.5mA (D0, D2 - D7, and CL)
V _{OLCS}	SDA low -level output voltage	V _{SS}	-	0.2 X V _{DD}	V	V _{DD} <2V I _{OL} =2mA (SDA)
				0.4		V _{DD} >2V I _{OL} =3mA (SDA)
I _{LI}	Input leakage current	-1.0	-	1.0	μA	V _{IN} = V _{DD} or V _{SS} (A0, \overline{RD} (E), \overline{WR} (R/ \overline{W}), \overline{CS} , CLS, IM0~2 and \overline{RES}).
I _{Hz}	Hz leakage current	-1.0	-	1.0	μA	When the D0 - D7, and CL are in high impedance.
f _{OSC}	Oscillation frequency	648	720	792	kHz	T _A = +25°C.V _{DD} =3V
f _{FRM}	Frame frequency for 128 Commons	93.6	104	114.4	Hz	When f _{OSC} = 720kHz, Divide ratio = 1, common width = 54 DCLKs.
RON1	Common switch resistance	-	15	-	Ω	V _{pp} =15V,V _{com} =V _{ss} +0.4V
RON2	Common switch resistance	-	500	-	Ω	V _{pp} =15V,V _{COM} =0.770×V _{pp} -0.4V



AC Characteristics

(1) System buses Read/Write characteristics 1 (For the 8080 Series Interface MPU)

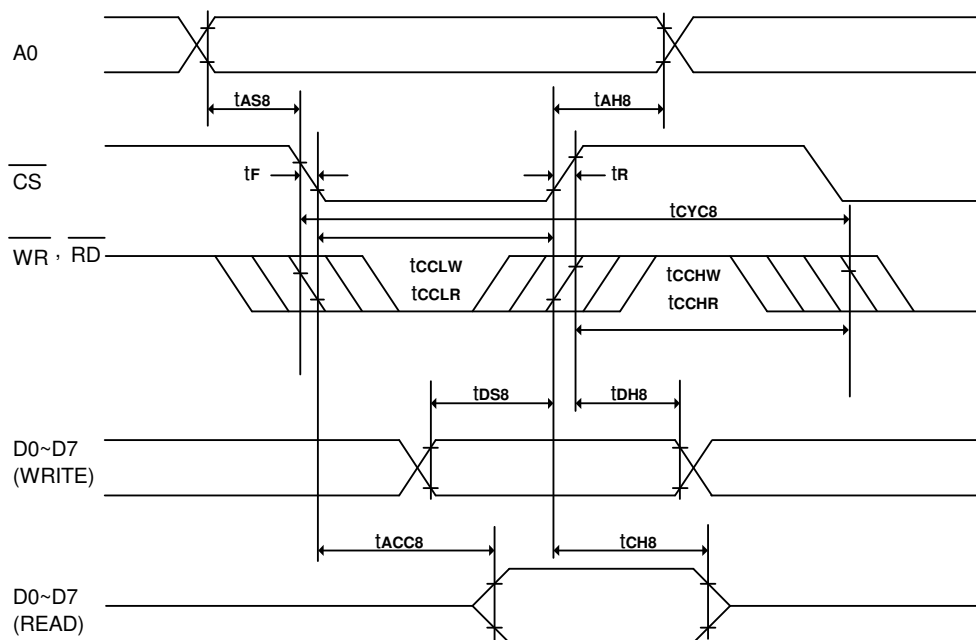

($V_{DD} = 1.65V - 2.4V, T_A = +25^\circ C$)

Symbol	Parameter	Min.	Typ.	Max.	Unit	Condition
t_{CYC8}	System cycle time	300	-	-	ns	
t_{AS8}	Address setup time	0	-	-	ns	
t_{AH8}	Address hold time	0	-	-	ns	
t_{DS8}	Data setup time	40	-	-	ns	
t_{DH8}	Data hold time	30	-	-	ns	
t_{CH8}	Output disable time	10	-	70	ns	$C_L = 100pF$
t_{ACC8}	\overline{RD} access time	-	-	280	ns	$C_L = 100pF$
t_{CCLW}	Control L pulse width (WR)	100	-	-	ns	
t_{CCLR}	Control L pulse width (RD)	120	-	-	ns	
t_{CCHW}	Control H pulse width (WR)	100	-	-	ns	
t_{CCHR}	Control H pulse width (RD)	100	-	-	ns	
t_R	Rise time	-	-	15	ns	
t_F	Fall time	-	-	15	ns	

(V_{DD} = 2.4V – 3.5V, T_A = +25°C)

Symbol	Parameter	Min.	Typ.	Max.	Unit	Condition
tcyc8	System cycle time	300	-	-	ns	
tAS8	Address setup time	0	-	-	ns	
tAH8	Address hold time	0	-	-	ns	
tDS8	Data setup time	40	-	-	ns	
tDH8	Data hold time	15	-	-	ns	
tCH8	Output disable time	10	-	70	ns	C _L = 100pF
tACC8	\overline{RD} access time	-	-	140	ns	C _L = 100pF
tcCLW	Control L pulse width (WR)	100	-	-	ns	
tcCLR	Control L pulse width (RD)	120	-	-	ns	
tcCHW	Control H pulse width (WR)	100	-	-	ns	
tcCHR	Control H pulse width (RD)	100	-	-	ns	
tR	Rise time	-	-	15	ns	
tF	Fall time	-	-	15	ns	



(2) System buses Read/Write Characteristics 2 (For the 6800 Series Interface MPU)

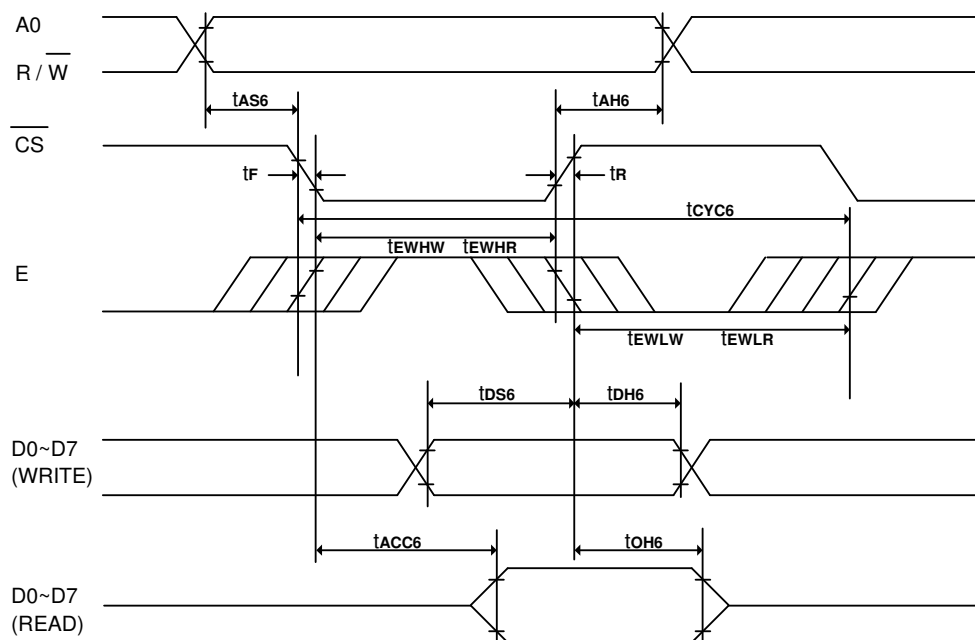

(VDD = 1.65 – 2.4V, TA = +25°C)

Symbol	Parameter	Min.	Typ.	Max.	Unit	Condition
tCYC6	System cycle time	300	-	-	ns	
tAS6	Address setup time	0	-	-	ns	
tAH6	Address hold time	0	-	-	ns	
tDS6	Data setup time	40	-	-	ns	
tDH6	Data hold time	30	-	-	ns	
tOH6	Output disable time	10	-	70	ns	CL = 100pF
tACC6	Access time	-	-	280	ns	CL = 100pF
tEWHW	Enable H pulse width (Write)	100	-	-	ns	
tEWHR	Enable H pulse width (Read)	120	-	-	ns	
tEWLW	Enable L pulse width (Write)	100	-	-	ns	
tEWLR	Enable L pulse width (Read)	100	-	-	ns	
tR	Rise time	-	-	15	ns	
tF	Fall time	-	-	15	ns	



SH1107

(VDD = 2.4 – 3.5V, TA = +25°C)

Symbol	Parameter	Min.	Typ.	Max.	Unit	Condition
tCYC6	System cycle time	300	-	-	ns	
tAS6	Address setup time	0	-	-	ns	
tAH6	Address hold time	0	-	-	ns	
tDS6	Data setup time	40	-	-	ns	
tDH6	Data hold time	15	-	-	ns	
tOH6	Output disable time	10	-	70	ns	CL = 100pF
tACC6	Access time	-	-	140	ns	CL = 100pF
tEWHW	Enable H pulse width (Write)	100	-	-	ns	
tEWHR	Enable H pulse width (Read)	120	-	-	ns	
tEWLW	Enable L pulse width (Write)	100	-	-	ns	
tEWLR	Enable L pulse width (Read)	100	-	-	ns	
tR	Rise time	-	-	15	ns	
tF	Fall time	-	-	15	ns	



(3) System buses Write characteristics 3 (For 4 wire SPI)

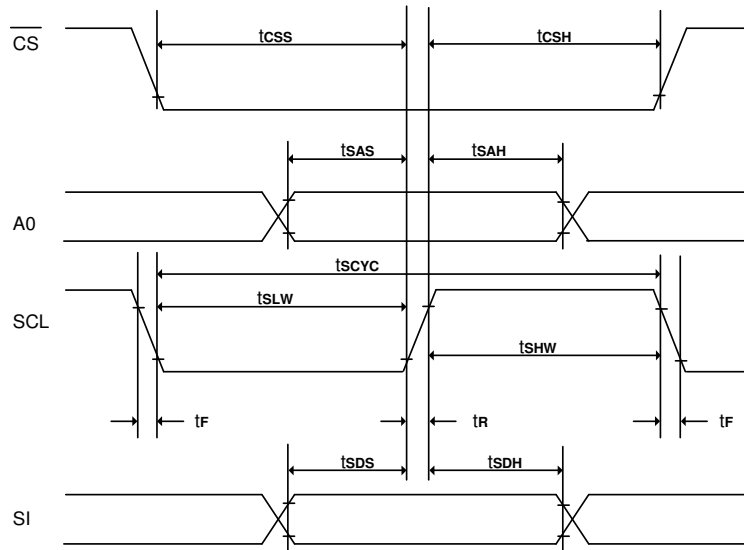

(VDD1 = 1.65 – 2.4V, TA = +25°C)

Symbol	Parameter	Min.	Typ.	Max.	Unit	Condition
tCYC	Serial clock cycle	500	-	-	ns	
tsAS	Address setup time	300	-	-	ns	
tsAH	Address hold time	300	-	-	ns	
tSDS	Data setup time	200	-	-	ns	
tSDH	Data hold time	200	-	-	ns	
tCSS	\overline{CS} setup time	240	-	-	ns	
tCSH	\overline{CS} hold time time	120	-	-	ns	
tSHW	Serial clock H pulse width	200	-	-	ns	
tSLW	Serial clock L pulse width	200	-	-	ns	
tR	Rise time	-	20	30	ns	
tF	Fall time	-	20	30	ns	

(VDD1 = 2.4 - 3.5V, TA = +25°C)

Symbol	Parameter	Min.	Typ.	Max.	Unit	Condition
tCYC	Serial clock cycle	250	-	-	ns	
tsAS	Address setup time	150	-	-	ns	
tsAH	Address hold time	150	-	-	ns	
tSDS	Data setup time	100	-	-	ns	
tSDH	Data hold time	100	-	-	ns	
tCSS	\overline{CS} setup time	120	-	-	ns	
tCSH	\overline{CS} hold time time	60	-	-	ns	
tSHW	Serial clock H pulse width	100	-	-	ns	
tSLW	Serial clock L pulse width	100	-	-	ns	
tR	Rise time	-	10	15	ns	
tF	Fall time	-	10	15	ns	



(4) System buses Write characteristics 4(For 3 wire SPI)

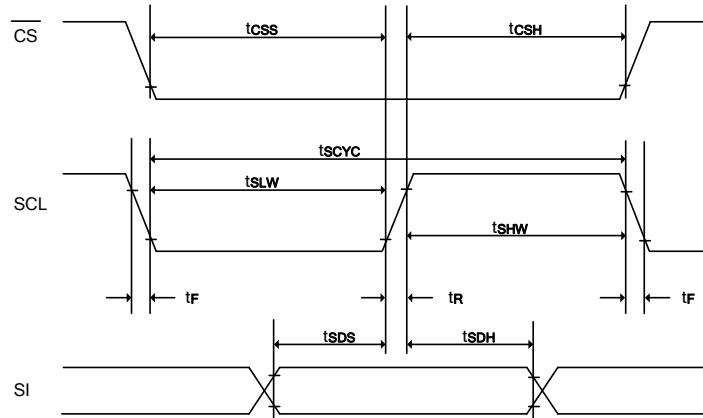

(VDD1 = 1.65 – 2.4V, TA = +25°C)

Symbol	Parameter	Min.	Typ.	Max.	Unit	Condition
tSCYC	Serial clock cycle	500	-	-	ns	
tSDS	Data setup time	200	-	-	ns	
tSDH	Data hold time	200	-	-	ns	
tcSS	$\overline{\text{CS}}$ setup time	240	-	-	ns	
tcSH	$\overline{\text{CS}}$ hold time time	120	-	-	ns	
tSHW	Serial clock H pulse width	200	-	-	ns	
tSLW	Serial clock L pulse width	200	-	-	ns	
tR	Rise time	-	-	30	ns	
tF	Fall time	-	-	30	ns	

(VDD1 = 2.4 - 3.5V, TA = +25°C)

Symbol	Parameter	Min.	Typ.	Max.	Unit	Condition
tSCYC	Serial clock cycle	250	-	-	ns	
tSDS	Data setup time	100	-	-	ns	
tSDH	Data hold time	100	-	-	ns	
tcSS	$\overline{\text{CS}}$ setup time	120	-	-	ns	
tcSH	$\overline{\text{CS}}$ hold time time	60	-	-	ns	
tSHW	Serial clock H pulse width	100	-	-	ns	
tSLW	Serial clock L pulse width	100	-	-	ns	
tR	Rise time	-	-	15	ns	
tF	Fall time	-	-	15	ns	



(5) I²C interface characteristics

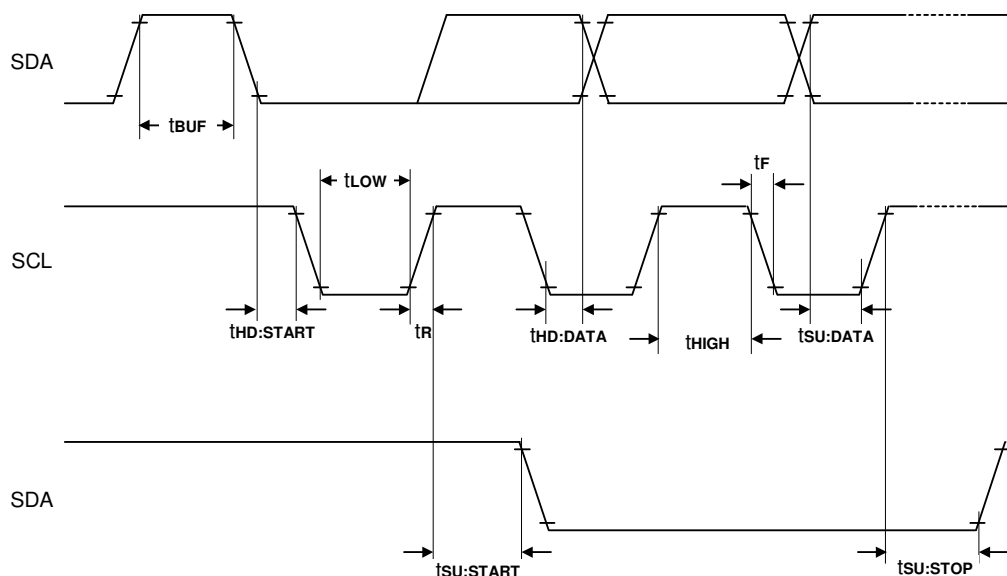

(V_{DD} = 1.65 - 3.5V, T_A = +25°C)

Symbol	Parameter	Min.	Typ.	Max.	Unit	Condition
f _{SCL}	SCL clock frequency	DC	-	400	kHz	
T _{LOW}	SCL clock Low pulse width	1.3	-	-	μs	
T _{HIGH}	SCL clock H pulse width	0.6	-	-	μs	
T _{SU:DATA}	data setup time	100	-	-	ns	
T _{HD:DATA}	data hold time	0	-	0.9	μs	
T _R	SCL · SDA rise time	20+0.1Cb	-	300	ns	
T _F	SCL · SDA fall time	20+0.1Cb	-	300	ns	
C _b	Capacity load on each bus line	-	-	400	pF	
T _{SU:START}	Setup time for re-START	0.6	-	-	μs	
T _{HD:START}	START Hold time	0.6	-	-	μs	
T _{SU:STOP}	Setup time for STOP	0.6	-	-	μs	
T _{BUF}	Bus free times between STOP and START condition	1.3	-	-	μs	



(6) Reset Timing

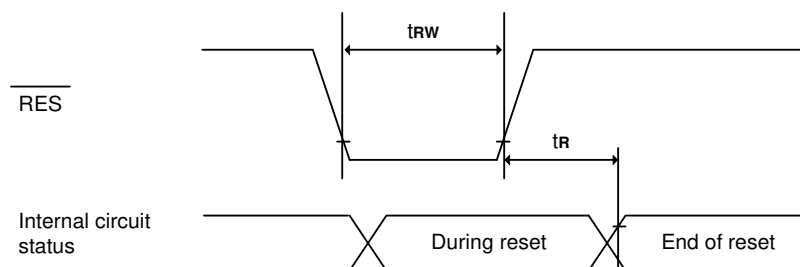

($V_{DD} = 1.65 - 3.5V$, $T_A = +25^{\circ}C$)

Symbol	Parameter	Min.	Typ.	Max.	Unit	Condition
t_R	Reset time	-	-	2.0	μs	
t_{RW}	Reset low pulse width	10.0	-	-	μs	



Application Circuit (for reference only)

Reference Connection to MPU:

1. 8080 series interface: (Internal oscillator, External Vpp)

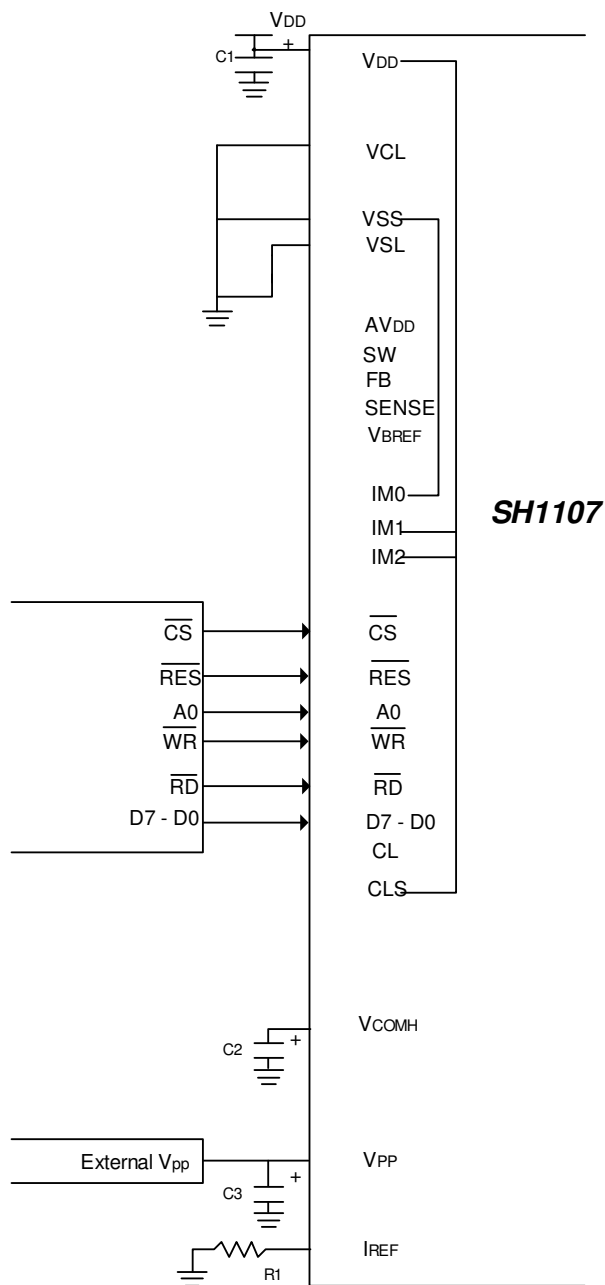

Figure 18-1

Note:

C1 - C3: 4.7μF.

R1: about 750KΩ (Refer to the table8), $R1 = (\text{Voltage at } I_{REF} - V_{SS})/I_{REF}$



2. 6800 Series Interface: (Internal oscillator, Built-in DC-DC)

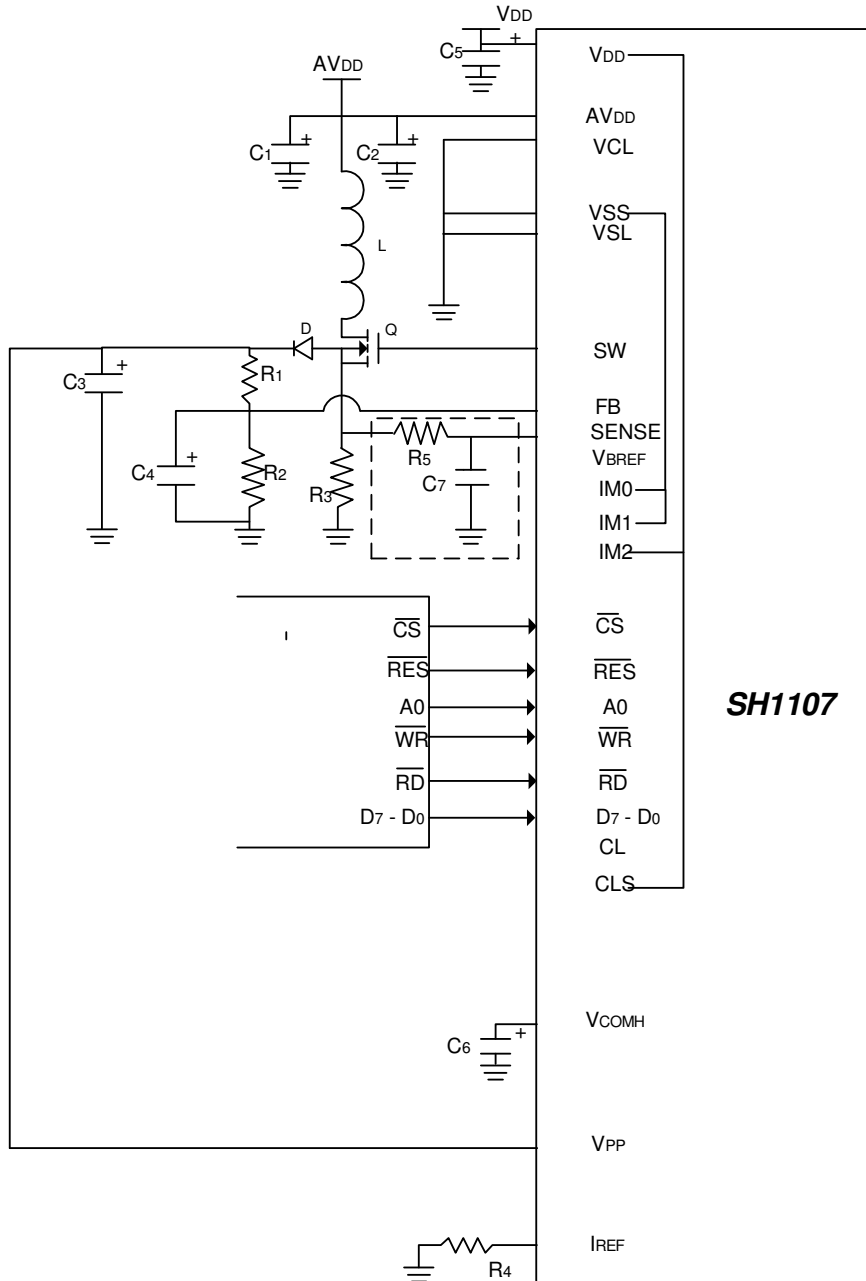

Figure 18-2

Note:

L, D, Q, R1, R2, R3, R5 and C1---C4, C7: Please refer to following description of DC-DC module.

C6:4.7 μ F

R4: about 750K Ω (Refer to the table8), $R4 = (\text{Voltage at } I_{REF} - V_{SS})/I_{REF}$



3. Serial Interface (3-wire or 4-wire SPI): (External oscillator, External V_{PP}, Max 16.5V)

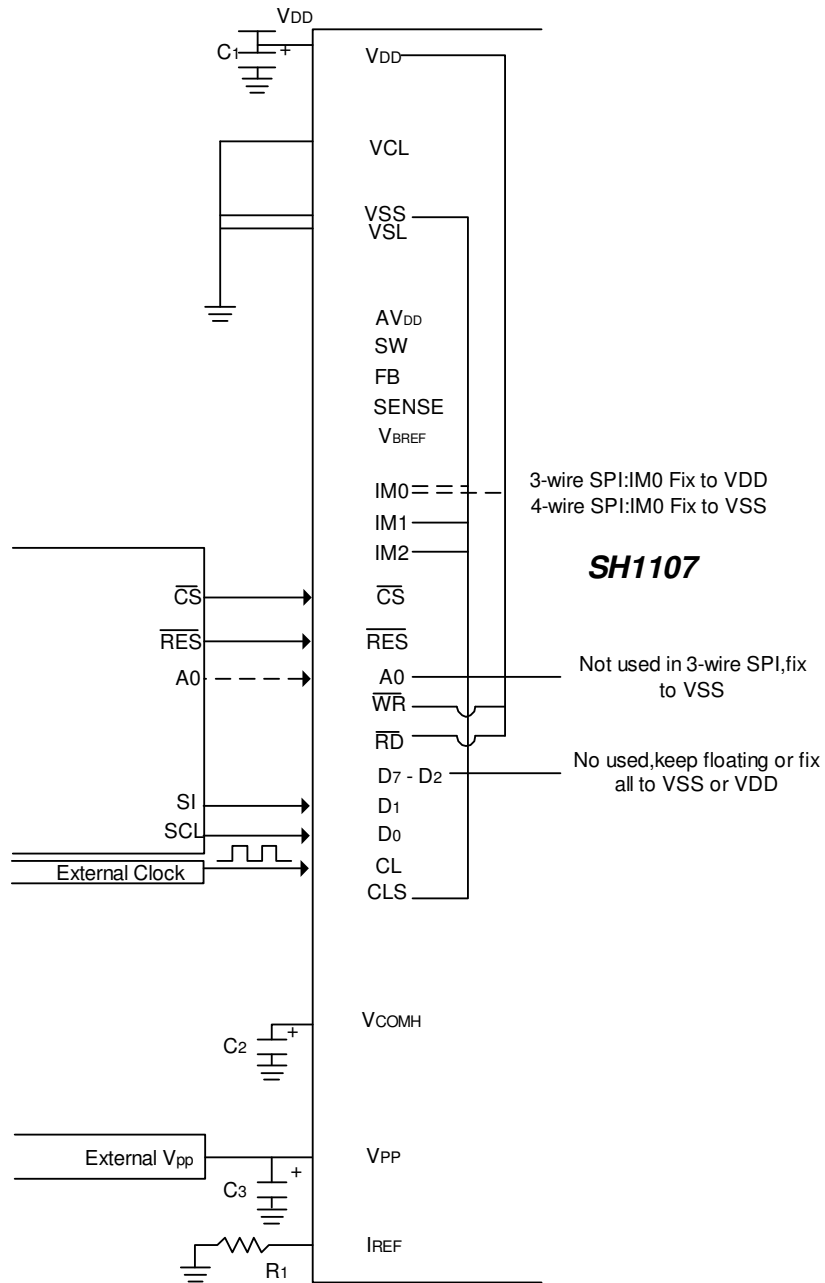

Figure 18-3

Note:

C1---C3: 4.7 μ F

R1: Recommend 750KΩ (Refer to the table8)



4. I²C Interface (Internal oscillator, External VPP, Max 16.5V)

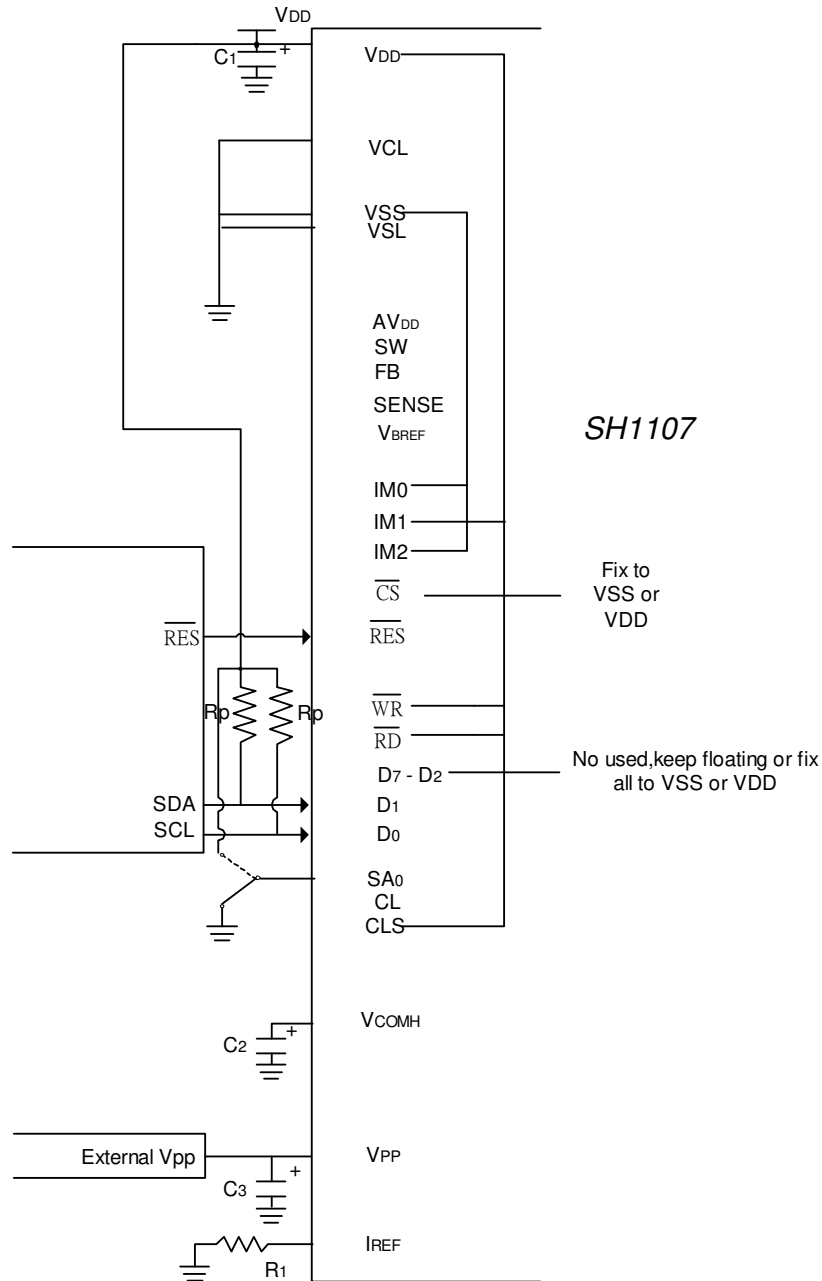

Figure 18-4

Note:

C1---C3:4.7 μ F

R1: Recommend 750KΩ (Refer to the table8)

The least significant bit of the slave address is set by connecting the input SA0 to either logic 0(VSS) or 1(VDD)

The positive supply of pull-up resistor must equal to the value of VDD

Recommend the value of resistor Rp equal to 1.5 KΩ



DC-DC

Below application circuit is an example for the input voltage of 3V AVDD to generate Vpp of about 15V@10mA-25mA application

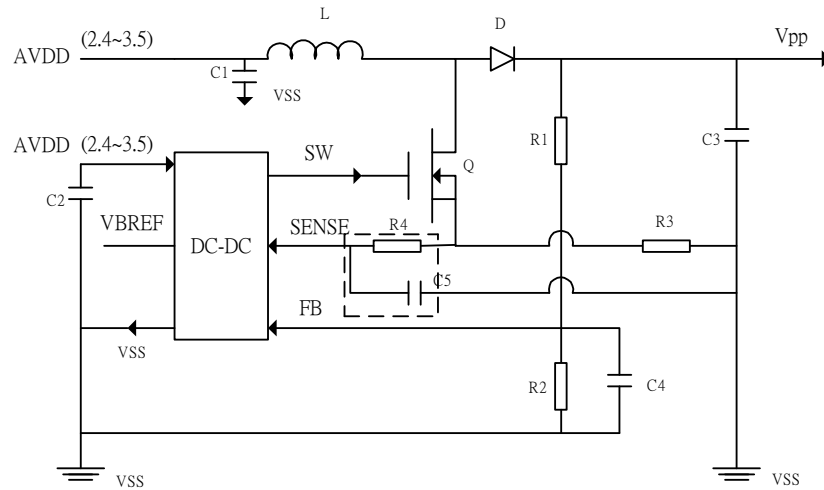

Figure 19

Symbol	Value	Recommendation
L	10 μ H	
D	SCHOTTKY DIODE	20V@0.5A, MBR0520
Q	MOSFET	N-FET with low RDS(ON),MGSF1N02LT1
R1	1.1M	1%,1/8W
R2	100K	1%,1/8W
R3	0.12	1%,1/2W
R4	10K	1%,1/8W
C1	22 μ F	Ceramic/16V
C2	0.1 μ F	Ceramic/16V
C3	10 μ F	Low ESR/16V
C4	56pF	Ceramic/16V
C5	220pF	Ceramic/16V

Note: R4&C5 are optional; they can increase the efficiency of inductance



SH1107

Ordering Information

Part No.	Package
SH1107G	Gold bump on chip tray

**Data Sheet History**

Version	Contents	Date
2.3	P52: Added 4-wire SPI Write characteristics t_{R} and t_{F} typ. P47: Added f_{OSC} max and min value P47: Added f_{FRM} max and min value	Aug.2017
2.2	P6: modify chip size (Y=670 μm).	Aug.2016
2.1	P1: Added "multiplexing ratio and Vertical scrolling" description. P30: Added command "Multiplex Raiton". P31: Added command "Display Offset". P38: Added command "Set Display Start Line". P42: Modify command list.	Dec.2014
2.0	P31: modify the max. value of SF P46: modify the the value of IOL when $V_{\text{DD1}} < 2\text{V}$	Dec. 2013
1.0	Original	Jun. 2013